



AS/10-0281/10-0284/10-028 Alarm Station

"The Art of Gas Detection"



Four light Alarm Bar with Horn



Two light Alarm Bar with Horn

Div 2 rated Quick Connect and cable option allows bars to be "daisy chained" to provide annunciation at multiple locations from the same alarm relays

Sounder Features

Maximum output: 125dB(A) @ 1 meter
 No. of tones: 28
 No. of stages: 3
 Voltages DC: 12-48V
 Voltages AC: Up to 254V
 Ingress protection: IP66 and IP67, NEMA 4X and 6
 Certifications: Class I, Div. 2 Groups A, B, C, & D
 Temperature: -55°C to +70°C
 Housing Material:
 Enclosure: Glass reinforced polyester
 Flare: High impact thermoplastic polyester
 Mounting Bracket: Stainless Steel

Strobe Features

Class I, Div. 2 Groups A, B, C, & D
 NEMA 4X
 10,000 hour Xenon strobe lamp
 Solid state circuitry
 Potted power supply
 Available in six lens colors
 Certified temperature -40°C to +65°C
 50 effective candlepower
 1.9 joules per flash. 190,000 Peak Candlepower
 60 to 80 flashes per minute

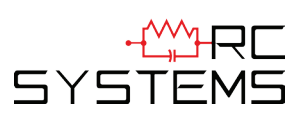
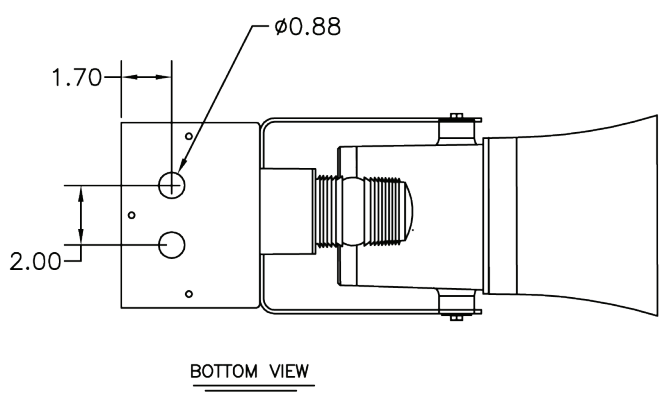
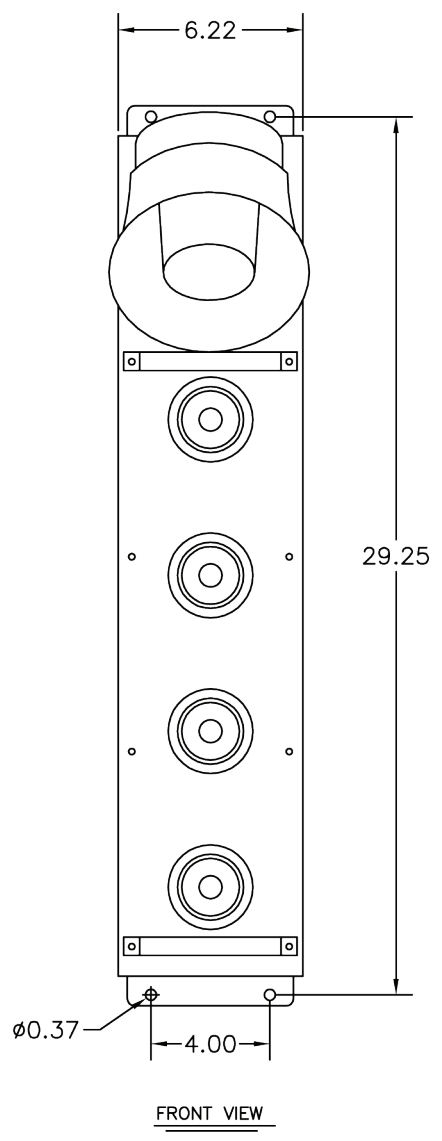
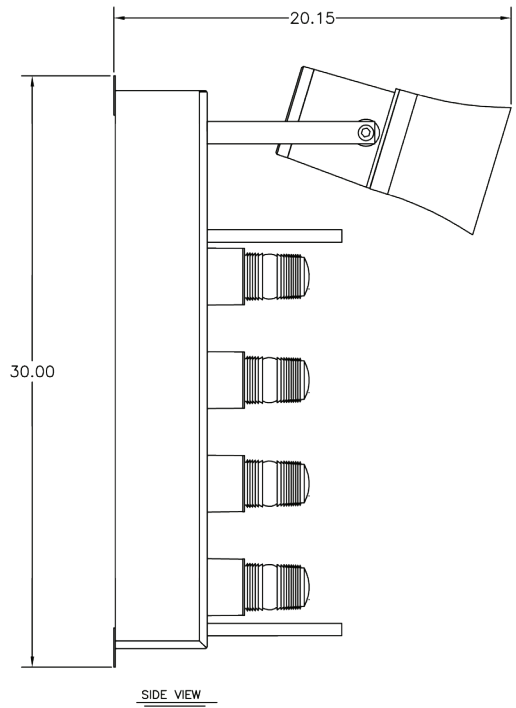

8621 Highway 6, Hitchcock, TX 77563
 Tel: (409) 986-9800 • Fax: (409) 986-9880
 www.rcsystemsco.com