

INSTRUCTION MANUAL

R.C. SYSTEMS CO. INC.

MODEL ST-90/DUAL TWO CHANNEL CONTROLLER

(Revision 3.5; Beginning Firmwares 2.08)



Warning: Read & understand contents of this manual prior to operation. Failure to do so could result in serious injury or death.

PH. 409-986-9800 FAX 409-986-9880
8621 HWY 6 HITCHCOCK, TX 77563
Website: <http://www.rcsystemsco.com>

SECTION 1	1
IMPORTANT SAFETY ISSUES.....	1
1.0 GENERAL DESCRIPTION.....	2
1.1 DATA DISPLAY SCREENS.....	3
1.1.1 MAIN DATA SCREEN.....	4
1.1.2 TREND SCREEN.....	4
1.1.3 BLIND MODE SCREEN.....	4
1.2 SPECIFICATIONS:.....	5
1.2.1 POWER SUPPLY REQUIREMENTS.....	5
1.2.2 RELAYS.....	5
1.2.3 AMBIENT TEMPERATURE RANGE.....	6
1.2.4 HUMIDITY RANGE.....	6
1.2.5 ALTITUDE.....	6
1.2.6 HOUSINGS / INSTALLATION CATEGORIES.....	6
1.2.7 APPROVALS.....	6
SECTION 2.....	6
2.0 BASIC OPERATION.....	6
2.1 SETUP MENU CONFIGURATION.....	7
2.2 CHANGING MENU VARIABLES USING THE KEYPAD.....	9
2.2.1 ST-90 SETUP CONFIGURATION MENUS.....	9
2.2.2 CHANNEL SETUP ENTRY MENU.....	9
2.2.3 ALARM 1 / ALARM 2 / ALARM 3 SET-UP MENUs.....	10
2.2.4 CONFIGURE MENU TO DEFINE CHANNEL.....	11
2.2.4a NAME / EUNITS ASCII DATA FIELDS.....	11
2.2.4b INPUT MEASUREMENT RANGE.....	11
2.2.4c DECIMAL POINT RESOLUTION.....	12
2.2.4d TURNING OFF UNUSED CHANNELS.....	12
2.2.5 CAL SETUP MENU.....	12
2.2.6 CALIBRATE INPUT MENU.....	13
2.3 SYSTEM CONFIGURATION MENUS.....	14
2.3.1 RELAY 1 / RELAY 2 MENUS.....	15
2.3.2 HORN / PIEZO MENU.....	16
2.3.3 COMM PORT MENU.....	16
2.3.4 CLOCK / DELAYS MENU.....	17
2.3.5 DIAGNOSTICS MENU.....	17
2.4 SYSTEM SECURITY MENU.....	19
SECTION 3.....	19
3.0 MOTHERBOARD INTERFACE PCB # 10-0215.....	19
3.1 INPUT / OUTPUT OPTIONAL PCB's.....	22
3.1.1 OPTIONAL ANALOG INPUT PCB # 10-0221-2.....	22
3.1.2 OPTIONAL BRIDGE / EC SENSOR INPUT BOARD #10-0216.....	23
3.1.3 OPTIONAL BRIDGE SENSOR INPUT BOARD #10-0219.....	24
3.1.4 BRIDGE SENSOR INITIAL SETUP.....	25
3.1.5 OPTIONAL ELECTROCHEMICAL SENSOR INPUT BOARD #10-0220.....	26
3.1.6 OPTIONAL DISCRETE RELAY PCB's #'s 10-0222.....	27
3.1.7 OPTIONAL 4-20mA ANALOG OUTPUT BOARD #10-0223.....	28
3.2 MODBUS RS-232 / RS-485 INTERFACE OPTION 10-0253.....	29
3.2.1 MODBUS REGISTER AND FUNCTION CODE SUMMARY.....	30
3.3 OPTIONAL EXTERNAL 24VDC 50 WATT POWER SUPPLIES.....	33
SECTION 4.....	33
4.0 ST-90N4 NEMA 4X WALL MOUNT ENCLOSURE.....	33
4.1 ST-90XP NEMA 7 EXPLOSION-PROOF WALL MOUNT ENCLOSURE.....	35
4.2 ST-90PY NEMA 4X POLYCARBONATE WALL MOUNT ENCLOSURE.....	35
4.3 ST-90PCS NEMA 4 PAINTED STEEL WALL MOUNT ENCLOSURE.....	37
4.4 ST-90SS NEMA 4X STAINLESS STEEL WALL MOUNT ENCLOSURE.....	38

SECTION 1

IMPORTANT SAFETY ISSUES

The following terms and symbols are used in this manual to alert the operator of important instrument operating issues:



This symbol is intended to alert the user to the presence of important operating and maintenance (servicing) instructions.



This symbol is intended to alert the user to the presence of dangerous voltage within the instrument enclosure that may be sufficient magnitude to constitute a risk of electric shock.



This symbol signifies the system's ground terminal

DC refers to direct current voltages.

VAC refers to alternating voltages.

WARNINGS:



- **Shock Hazard** - Disconnect or turn off power before servicing this instrument.
- NEMA 4X wall mount models should be fitted with a locking mechanism after installation to prevent access to high voltages by unauthorized personnel (see Figure 4.0).
- Only the combustible monitor portions of this instrument have been assessed by CSA for 122.2 No. 152 performance requirements.
- This equipment is suitable for use in Class I, Division 2, Groups A,B,C and D or non-hazardous locations only.
- **WARNING- EXPLOSION HAZARD-** SUBSTITUTION OF COMPONENTS MAY IMPAIR SUITABILITY FOR CLASS I, DIVISION 2.
- **WARNING- EXPLOSION HAZARD-** DO NOT REPLACE FUSE UNLESS POWER HAS BEEN SWITCHED OFF OR THE AREA IS KNOWN TO BE NON-HAZARDOUS.
- **WARNING- EXPLOSION HAZARD-** DO NOT DISCONNECT EQUIPMENT UNLESS POWER HAS BEEN SWITCHED OFF OR THE AREA IS KNOWN TO BE NON-HAZARDOUS.
- Use a properly rated CERTIFIED AC power (mains) cable installed as per local or national codes.
- For DC powered units, DC power must be from a SELV rated source.
- A certified AC power (mains) disconnect or circuit breaker should be mounted near the controller and installed following applicable local and national codes. If

a switch is used instead of a circuit breaker, a properly rated CERTIFIED fuse or current limiter is required to be installed as per local or national codes. Markings for positions of the switch or breaker should state (I) for on and (O) for off.

- Clean using only a damp cloth with no solvents.
- Equipment not used as prescribed within this manual may impair overall safety.

1.0 GENERAL DESCRIPTION

The R. C. Systems Co. Inc. ST-90/DUAL Two channel Controller is designed to display, and control alarm event switching for two sensor points. Sensor signals may be input as 4-20mA from transmitters, or, several signal conditioning options (see section 3.1) are available to accept sensors directly. The ST-90 is equipped with three alarms per channel with features such as *ON / OFF* delays, latching relays and alarm *Acknowledge*. A dedicated horn driver circuit for a local audible annunciator is also standard. Two standard 5-amp alarm relays are configurable via the “alarm voting” menu to make relays trip based upon various alarm combinations. Real-Time Clock and Calendar are also standard. Options such as 4-20mA outputs, discrete relays for each alarm and audible annunciators are easily added. RS-485 (Modbus RTU) or Ethernet (Modbus TCP) ports are also available for sending data to PC’s, PLC’s, DCS’s, or other R. C. Systems controllers.

A 128 x 64 pixel graphic LCD readout displays monitored data as bar graphs, 30-minute trends and engineering units. System configuration is via user friendly menus and all configuration data is retained in non-volatile memory during power interruptions. The ST-90 front panel is shown below in Figure 1.0 displaying the bar graph data screen. The five button symbols below the display are magnetically activated using the supplied magnetic wand without opening the enclosure. Opening the enclosure door provides access to the “touch” keypad as shown in Figure 1.1.

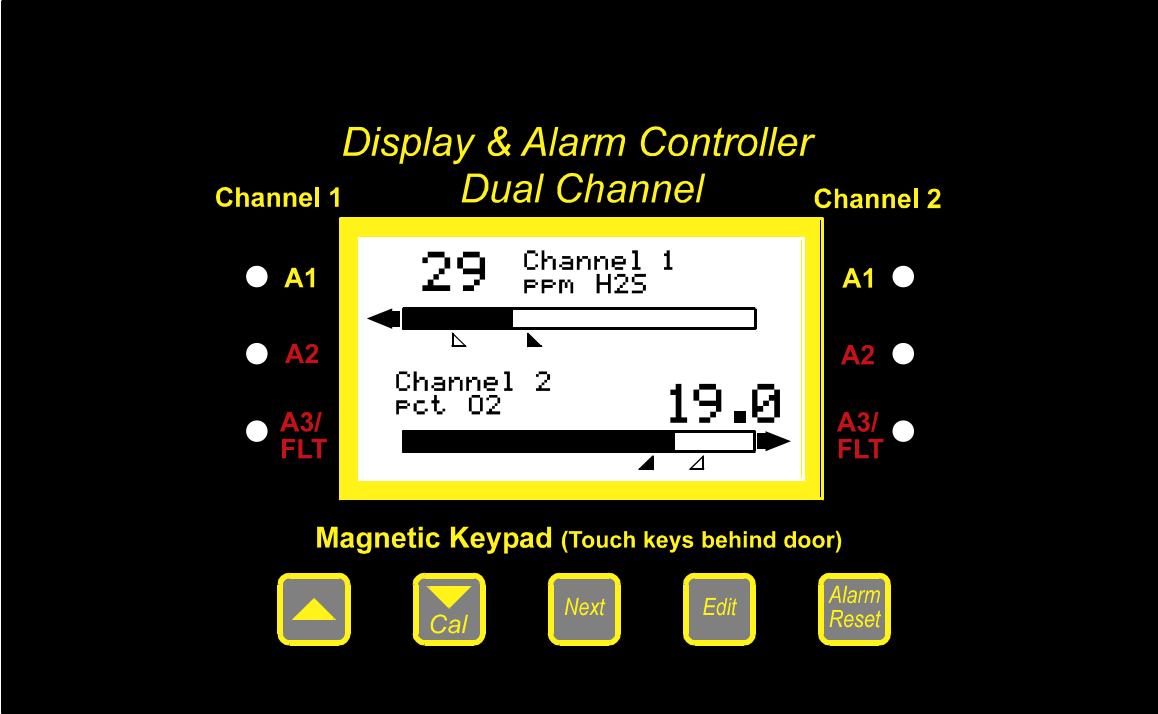

Figure1.0

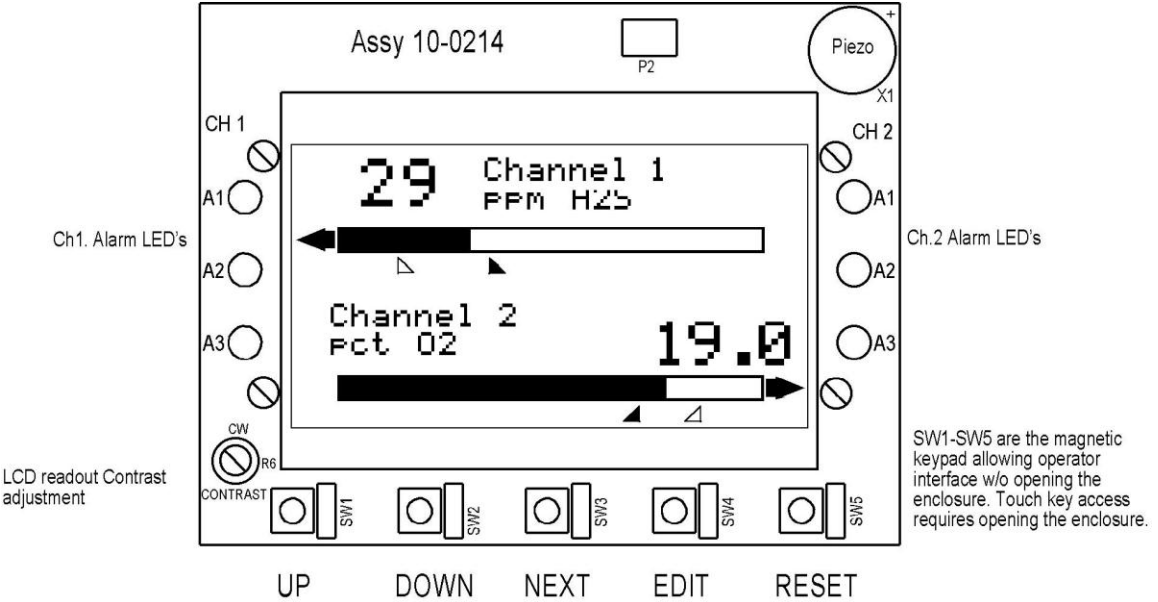

Figure1.1

1.1 DATA DISPLAY SCREENS

The ST-90 Controller offers three modes for displaying monitored data. Each are shown below in Figure 1.2.

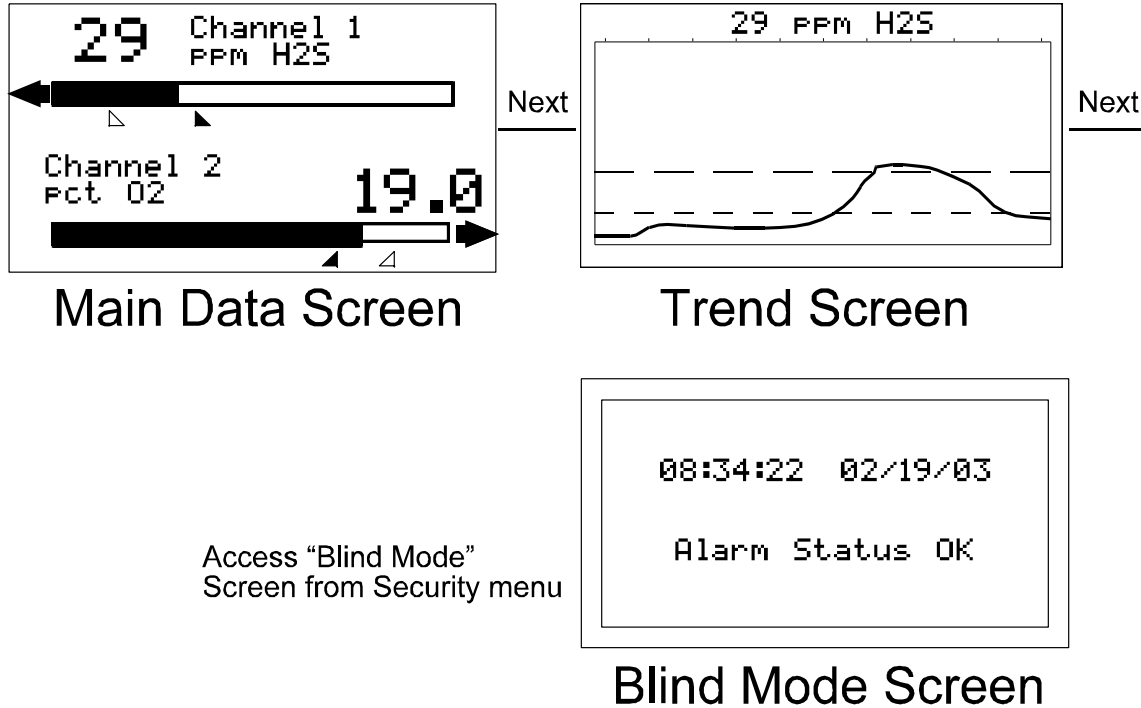

Figure 1.2

1.1.1 MAIN DATA SCREEN

The ST-90 Main Data screen shown at left in Figure 1.2 allows each channel to be viewed simultaneously. Engineering unit values and bar graph values are both displayed in real time. Arrows **below** the bars indicate alarm trip point values, making it easy to identify channels at or near alarm. The direction the horizontal 45 degree arrow side points indicates either a HIGH or LOW trip as illustrated in Figure 1.1 where Ch 1 points right indicating high level trips and Ch 2 points left indicating low level trips. Left and Right hand arrows located at the **ends** of each bar graph point towards Channel Alarm LED's on the front panel associated with this reading. The 10-digit ASCII fields for identifying engineering units and Channel ID for each channel are also shown on the Main Data screen.

1.1.2 TREND SCREEN

In addition to the Main Data screen described above, the ST-90 also provides 30-minute trend screens for each channel as shown in Figure 1.2. Data screens are selected by the NEXT key.

1.1.3 BLIND MODE SCREEN

The ST-90 Blind Mode screen shown at right in Figure 1.2 does not allow viewing of channel engineering unit values. It only indicates the system's alarm status and time / date. Some applications require only alarm status be displayed and prefer monitored values not be shown. A SECURITY menu (see section 2.40) allows locking all configuration parameters and having only the Blind Mode screen available for viewing.

1.2 SPECIFICATIONS:

1.2.1 POWER SUPPLY REQUIREMENTS

ST-90 primary power may be either 10-30 VDC or 100-240VAC. AC power requirements are 100-240 VAC 50/60 Hz @ .80 amp max (including inrush) and 40 watts max steady state, applied to TB5 on the motherboard. If AC power is not available the primary power may be 10-30 VDC applied to TB1 on the motherboard. A back-up DC power source may also be connected to TB1 for automatic switchover if the AC power source fails. See Figures 3.0 & 3.1 for wiring information.

The basic ST-90 consumes only 1.5 watts of 10-30 VDC power. Optional features such as relays and analog outputs increase power consumption as described below:

- 10-0221-2, **Analog Input PCB** option; add wattage for each monitor connected to this board's 24 VDC terminals.
- 10-0222, **Discrete Relay PCB** option; add 1.5 watt.
- 10-0223, **4-20mA Output PCB** option; add .5 watt.
- 10-0219, **Bridge Sensor Input PCB** option; add wattage of each sensor attached.

With an AC primary power source connected to TB1 on the motherboard, TB3 terminals 1 & 2 on the motherboard provide a maximum of 12 watts output power for powering of auxiliary external devices such as relays, lights and monitors (see Figure 3.0). Power consumed from TB3 must be included when calculating system power consumption.

IMPORTANT! TB3 only provides 24VDC power when AC is primary power.

24 VDC terminals on the 10-0221 Analog input option (see Figure 3.3) may also be used to power external transmitters and these loads must be calculated into the overall power budget. These terminals receive power from both the integral AC / DC power supply and the external TB1 supply as shown in Figure 3.0.

Some applications may require 24VDC power in excess of that available from the ST-90's integral AC power supply and thereby require an external AC/DC supply. NEC Class 2 FIFTY WATT external supplies are available for Division 1 (part # 10-0314) and Division 2 (part # 10-0315) potentially hazardous area installations and both also include a NEMA 4X weather rating. See complete specifications at:

http://www.rcsystemsco.com/rc/prod_view.asp?pid=25.

1.2.2 RELAYS

Two mechanical (dry contact) Common Form C relays are standard and may be mapped to various alarm events as described in section 2.3.1. ST-90's may also be equipped with optional solid-state common Form A relays (see order guide for details) in applications requiring non-arcing switching. Solid-state relays are recommended for switching of highly inductive loads.

A six mechanical (dry contact) Discrete Relay option board (see section 3.1.6) provides dedicated Form C relays for ALARM 1, ALARM 2 and FAULT for both channels.

All mechanical (dry contact) relays are rated at 5 Amp for 28 VDC and 250 ~VAC **RESISTIVE** loads. **IMPORTANT:** Appropriate diode (DC loads) or MOV (AC



loads) snubber devices must be installed with inductive loads to prevent RFI noise spikes. Optional solid state relays are rated at 2 Amp 12-280 ~VAC (600Vpk). Relay wiring should be kept separate from low level signal wiring.

1.2.3 AMBIENT TEMPERATURE RANGE

-25 to 60 degrees C

1.2.4 HUMIDITY RANGE

0 TO 90% R. H. Non-Condensing.

1.2.5 ALTITUDE

Recommended up to 2000 meters

1.2.6 HOUSINGS / INSTALLATION CATEGORIES

- *NEMA 4X wall mount. DIV 2 Groups A,B,C,D; Category II and pollution degree 3; NEMA 4X; IP66
- *NEMA 7 wall mount for DIV 1 & 2 Groups B,C,D; includes 'O' Ring in door to satisfy NEMA 4 rating.

*Includes standard non-intrusive magnetic keypad.

1.2.7 APPROVALS

CSA C22.2 No 1010.1 and ISA S82.02; CSA C22.2 No 152 for combustibles; UL 1604 / C22.2 No 213 (Div 2 Groups A,B,C,D); EN55011 & EN61000 (CE Mark). CSA File # = 219995 and may be seen at: CSA-International.org.

SECTION 2

2.0 BASIC OPERATION

The ST-90's graphic LCD displays monitored data and with the 5-button keypad also serves as the system's operator interface. All ST-90 configuration variables are entered with this operator interface using SETUP menus accessed by pressing **EDIT** from either data screen. This *Setup* mode may be exited manually by pressing **NEXT**, or automatically when no keys are pressed for 5 minutes. Alarm relays and front panel alarm LED indicators remain active during the *Setup* mode. Alarm LED's flash upon new alarms and become steady after *Acknowledged* by pressing the **ALARM RESET** key. A **SECURITY** menu offers a password feature to prevent tampering with ST-90 parameters.

Several signal conditioning input options are available to allow the ST-90 accept sensor and other analog signals directly (see section 3.1). A "sign-on" screen appears briefly after power is applied that indicates what type input / output options the unit is configured with.

2.1 SETUP MENU CONFIGURATION

Variables inside the **CHANNEL** (see section 2.2) and **SYSTEM** (see section 2.3) menu trees allow ST-90 configuration for a wide range of monitoring applications. Select the desired menu by scrolling with **UP/DOWN** and then **EDIT** to enter each menu. Figure 2.0 illustrates the menus tree for configuring *Channel* variables on its right side and *System* specific variables on the left side. *Channel* variables affect only the specific channel selected while *System* variables are related to features not specific to either channel.

2.2 CHANGING MENU VARIABLES USING THE KEYPAD

Upon entering a menu, a pointer controlled by the **UP/DOWN** keys indicates the selected variable. Some are simple **YES/NO** or **ON/OFF** entries toggled by pressing the **EDIT** key. Others, such as *Channel ID* and *Eunits* fields may have many ASCII character possibilities. Allowed ASCII characters are as follows:

ABCDEFGHIJKLMNOPQRSTUVWXYZ[\]^_`abcdefghijklmnopqrstuvwxyz blank
space !"#%&`()*+,-./0123456789:;<=>?@. Notice the often used *blank* character is located after lower case **z** and before the exclamation point **!**. **EDIT** places a cursor under the item and **UP/DOWN** scrolls through each allowed entry. The **NEXT** key moves the cursor to the next position within a field. When the field is complete, **EDIT** clears the cursor and loads the field into non-volatile memory where it is retained indefinitely. Without a cursor present, the **NEXT** key closes open menus in reverse order and returns the LCD to the data display.

2.2.1 ST-90 SETUP CONFIGURATION MENUS

The **SETUP** menu shown in the middle of Figure 2.0 and in Figure 2.1 below is reached by pressing **EDIT** with any data display present. This is the entry-level screen to **ALL Channel**, **System** and **Security** menus. It also shows the revision of firmware operating in the ST-90. Use the **UP/DOWN** keys to move the pointer to the desired menu and press the **EDIT** key.

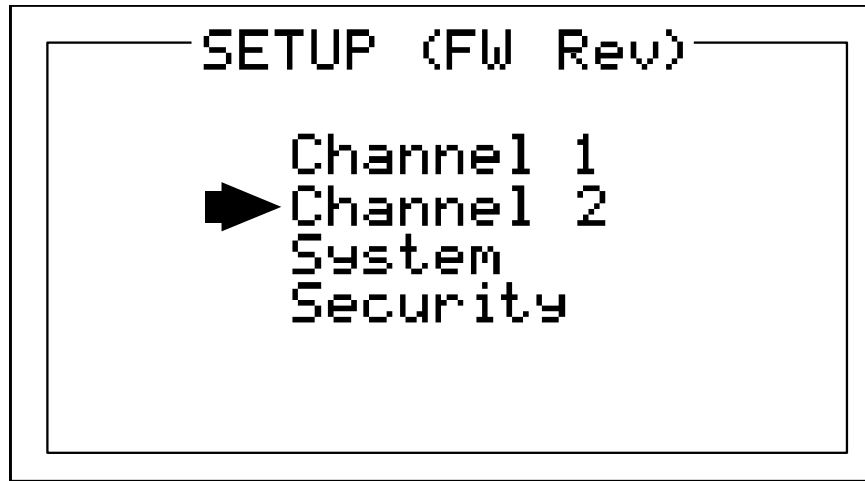

Figure 2.1

2.2.2 CHANNEL SETUP ENTRY MENU

The **CHANNEL** menu shown below in Figure 2.2 allows configuration of all variables for the selected channel. These are **Alarm 1**, **Alarm 2**, **Alarm 3**, **Configure** and **Calibrate**.

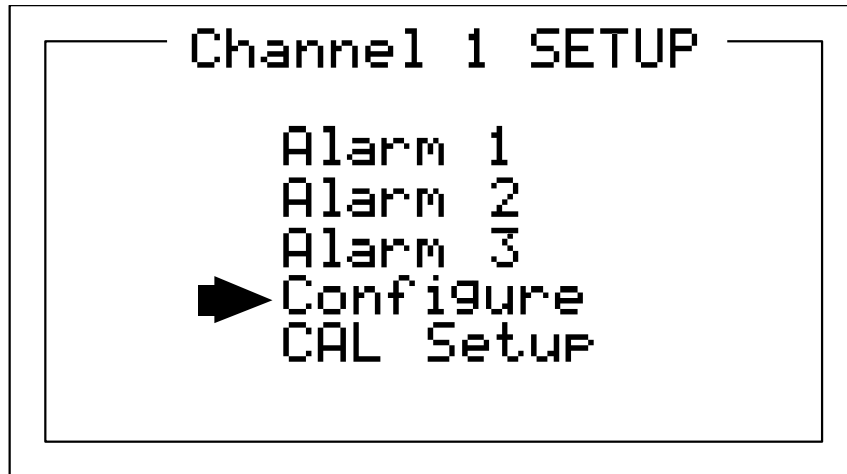

Figure 2.2

2.2.3 ALARM 1 / ALARM 2 / ALARM 3 SET-UP MENUS

Alarms 1, 2 and 3 have identical menus. The only difference between each is A1 front panel LED indicators are yellow while A2's and A3's are red. Typical applications often have A1 set at a WARN level, A2 at a HIGH level and A3 at a negative FAULT level. However, it is important to understand there is no functional difference between A1, A2 and A3. Since their configuration menus are identical, only one is shown in Figure 2.3.

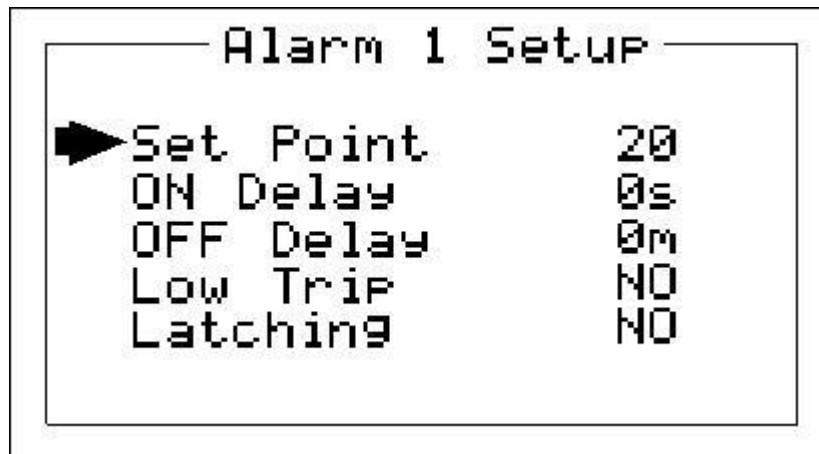

Figure 2.3

- **Set Point** is entered in engineering units and determines the value where the alarm trips. For example, if a channel monitors 0-50 ppmH₂S and the desired alarm level is 10 ppm, the correct entry is 10.00. A one percent dead band prevents alarm chatter. This means after tripping an alarm the input must move at least 1% of full scale back through the setpoint for the alarm to auto reset.
- The **ON Delay / OFF Delay** entries allow **ON** and **OFF** time delays affecting how long the trip-point must be surpassed before an alarm event transition occurs. **ON** delays are limited to 10 seconds while **OFF** delays may be as long as 120 minutes. Delays are useful in many applications to prevent nuisance alarms and unwanted cycling into and out of alarm conditions.

- **Low Trip** is set for **NO** for increasing alarms or **YES** for decreasing alarms to determine if the alarm activates upon exceeding or falling below the set-point.
- **Latching** determines either manual or automatic alarm reset operation. **YES** requires a manual **Alarm Reset** to unlatch the alarm even though an alarm condition no longer exists. **YES** also causes this alarm's common relay, front panel LED, and optional discrete relay to latch. **NO** allows all outputs for this alarm to automatically reset after the alarm condition clears.

Discrete LED indicators on the front panel indicate the status of each alarm. Any *new* alarm event causes the associated LED to flash until an **Alarm Reset** occurs causing an *acknowledged* steady on condition. Operators should recognize *new* alarms by a flashing LED. **Alarm Reset** also *acknowledges*, or deactivates, audible devices driven by the AUDIBLE ALARM option connector J2 (see Figure 3.1)

2.2.4 CONFIGURE MENU TO DEFINE CHANNEL

The channel setup menu after the alarm menus is **CONFIGURE**. It allows setting *Name* and *EUNIT* ASCII fields, defining the measurement range, and how many decimal points of resolution the reading will have.

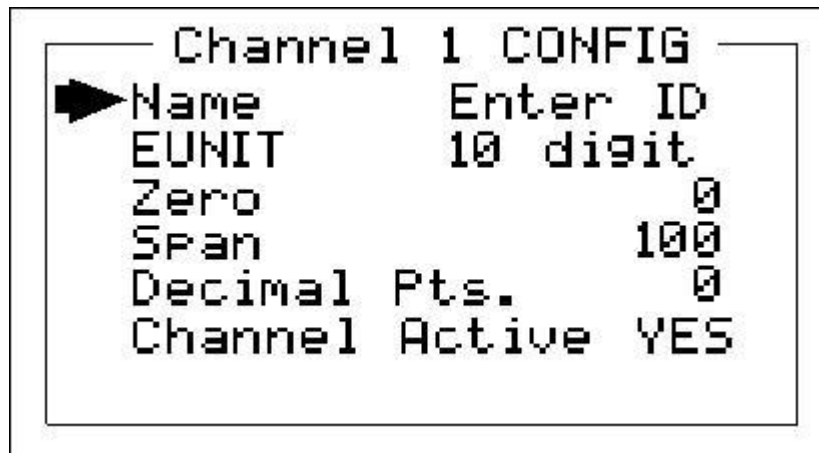

Figure 2.4

2.2.4a NAME / EUNITS ASCII DATA FIELDS

The first two items in this menu are for entering the 10 character channel *Name* and *engineering unit* ASCII fields. *Name* should describe the channel's data in user terminology such as tag # or other description. *Eunits* should define the units of measure for what this channel is to display. Several standard *Eunits* fields are available by pressing **EDIT** but if these are inappropriate, a **CUSTOM** field allows editing of each character. Section 2.2 describes how to modify these fields using the keypad.

2.2.4b INPUT MEASUREMENT RANGE

The **ZERO / SPAN** menu entries allow configuration of the measurement range displayed by this channel. Measurement Range defines the range of the input signal's engineering units. For example, if a channel's input is 4-20mA from a transmitter monitoring 0 to 10ppm chlorine, then the **Zero** value should equal 0.000 and the **Span**

value equal 10.00. Four digits must be entered so trailing 0's may appear here that are not displayed on other data screens.

2.2.4c DECIMAL POINT RESOLUTION

Resolution of the displayed channel value is configured in this menu by setting the number digits trailing the decimal point. Displayed readings are limited to a maximum of four digits with a polarity sign. Auto-ranging displays the highest resolution allowed by this menu's decimal point entry. For example, a range of 0 to 100ppm and two decimal points reads **0.00** at 0ppm and **100.0** at 100ppm. This may be undesirable due to the high resolution at zero unless the sensor's output is extremely stable. If decimal points are limited to one, the 0ppm reading becomes **0.0** and the 100ppm reading remains **100.0**. Resolution may be limited further by setting decimal points to 0 where in the above example, 0ppm reads **0** and 100ppm reads **100**.

2.2.4d TURNING OFF UNUSED CHANNELS

The **Channel Active?** menu entry asks if this channel is to be utilized. **OFF** causes the controller to never process inputs applied to this channel and no alarms are tripped or data displayed. Inactive channels have a line drawn through them on the Setup screen to indicate it is turned off.

2.2.5 CAL SETUP MENU

The ST-90 CAL MODE feature supports pushbutton calibration of zero and span values. This feature should be utilized only when there are no other zero/span controls within the monitoring system since it is inappropriate to calibrate a signal at more than one point. Therefore, if calibration will be performed at another transmitter or monitoring device, the ST-90 CAL MODE feature should not be used.

The **CAL SETUP** menu allows entering the correct **Zero Gas** & **Span Gas** set-point values needed to calibrate the sensor. These are entered in the same engineering units as input range.

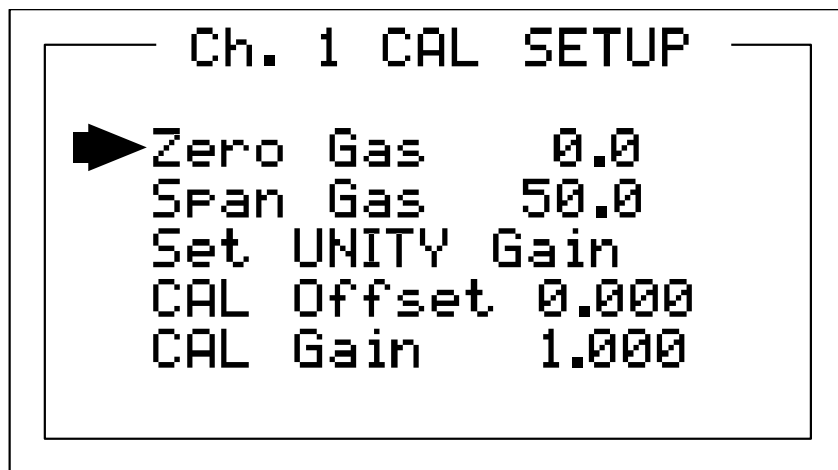

Figure 2.5

2.2.6 CALIBRATE INPUT MENU

Calibration is the most important function for insuring correct operation of ST-90's equipped with sensor inputs. The CAL MODE (flow chart shown in Figure 2.6) is designed to make calibration quick, easy and error free. A successful ZERO and SPAN calibration requires only five keystrokes. Optional 4-20mA outputs (if equipped) transmit 1.5mA during CAL MODE and 4mA during the subsequent CAL PURGE delay to prevent external alarms during calibration. Local ST-90 alarm relays are inhibited during CAL MODE. Unintentional calibrations may be reset by the **Set UNITY** menu item. **Set UNITY** resets **Cal OFFSET** to 0 & **Cal GAIN** to 1 which is useful for returning the calibration to a known starting place. Sensor aging may be monitored by recording zero and span readings at **Unity Gain** when the sensor is new, and again later when degradation may have occurred. CAL MODE automatically exits if no keystroke is detected after 5 minutes.

Follow these ST-90 sensor calibration guidelines:

- Calibration accuracy is only as good as the calibration standard accuracy. R. C. Systems recommends calibration standards with NIST (National Institute of Standards and Technology) traceable accuracy to increase the validity of the calibration.
- Do not use a gas cylinder beyond its expiration date.
- Calibrate a new sensor before use.
- Allow the sensor to stabilize before starting calibration (approximately 5 minutes).
- Calibrate on a regular schedule. (R. C. Systems recommends once every 3 months, depending on use and sensor exposure to poisons and contaminants.)
- Calibrate only in a clean atmosphere free of background gas.

Use the following step-by-step procedure to perform ZERO and SPAN calibrations.

1. To enter the CAL MODE from any data display, press the dual purpose DOWN / CAL key and within 5 seconds press the EDIT key.
2. Using the Cal-Cup and following the instructions on the screen, apply a clean ZERO gas or be sure there is no background target gas in the monitored area. After the reading is stable, (approximately 1 minute) press the EDIT key to perform a ZERO calibration.
3. If the ZERO calibration is successful, CAL MODE automatically proceeds to the SPAN check.
4. Apply the **correct** SPAN gas at .5 liters/min. After the reading is stable, (approximately 1 minute) press the EDIT key to perform a SPAN calibration. **WARNING:** The SPAN gas used must match the value specified since this is what the ST-90 will indicate after a successful SPAN calibration. The **Span Gas** value may be edited if it becomes necessary to apply a different gas concentration (see **Span Gas** in section 2.2.5).
5. If the SPAN calibration is successful, the display flashes "REMOVE CAL GAS" and starts the CAL PURGE delay.

6. CAL MODE will be complete after the end of the CAL PURGE delay.

The flow chart in Figure 2-6 illustrates the above procedure. **UP**, **CAL**, **NEXT** & **EDIT** labels indicate keystrokes (**CAL/DOWN** is a dual purpose key). The CAL MODE information screen (top of the chart) is available for advanced users to see Offset / Gain calibration constants and live analog to digital converter (A/D) counts. Span Gas calibration values may also be edited from this screen. Holding the **UP** key, for 5 seconds during CAL MODE, displays this screen. **Unity Gain** may be used at anytime to cancel incorrect calibrations and start again.

Unity Gain may be used at anytime to cancel incorrect calibrations and start again.

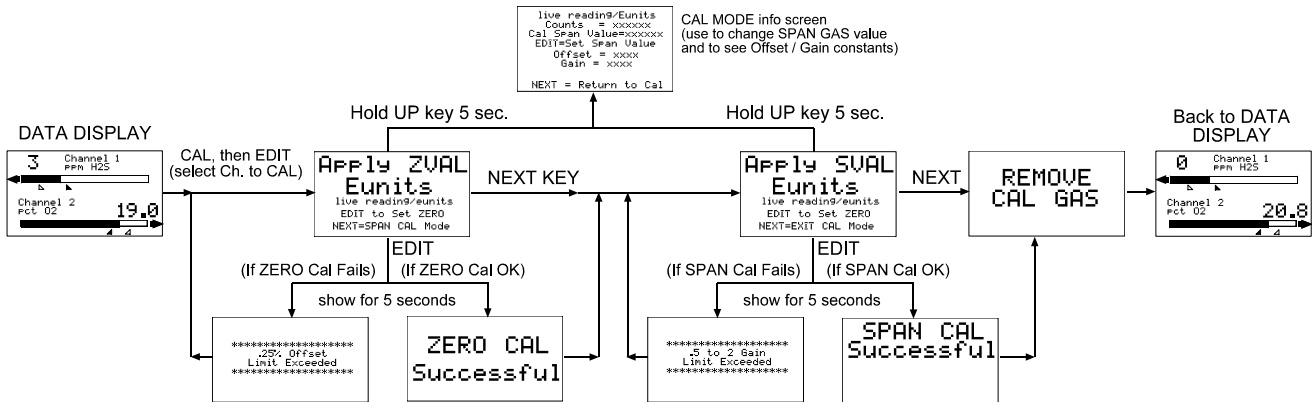

Figure 2.6

2.3 SYSTEM CONFIGURATION MENUS

Several items needing configuration are not specific to either channel but affect the entire ST-90 system. These are located in the *system* tree entry menu shown on the left side of Figure 2.0. System menus are accessed by pointing to the desired item and pressing **EDIT**. The **Diagnostics** menu group (section 2.3.5) is useful for testing relay and analog I/O without stimulating the input.

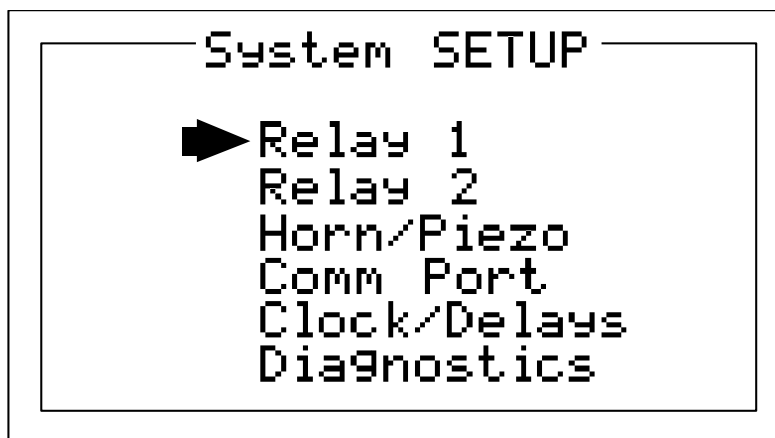

Figure 2.7

2.3.1 RELAY 1 / RELAY 2 MENUS

The **Relay 1** & **Relay 2** menus are identical except **Relay 2** has an *acknowledge* feature useful if it controls an audible device. All other **Relay 1** & **Relay 2** features are identical and therefore are discussed only once.

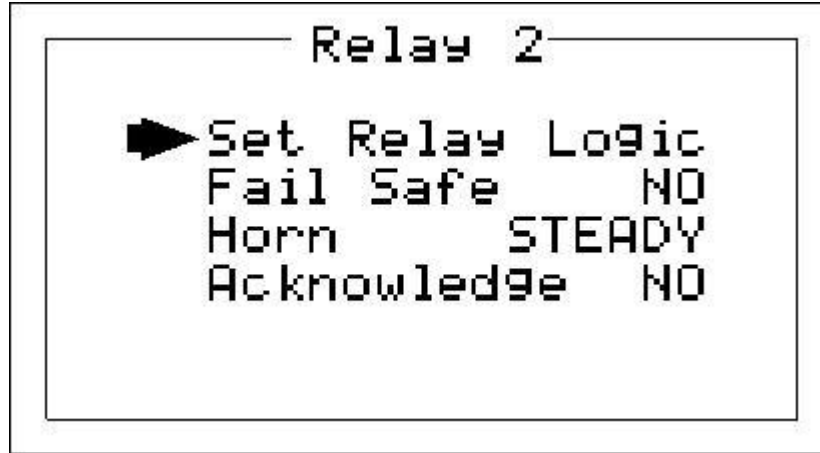

Figure 2.8

- The **Set Relay Logic** menu shown below in Figure 2.9 offers additional “voting” flexibility by controlling the channel alarm combinations that will trip this common alarm relay. “**OVR**” on the menu’s right side stands for *override* and means ANY of the selected alarms will activate the relay. The “**OR**” / “**AND**” columns work together based upon the following logic equation:

[AND column selections] ANDED WITH [OR column selections] = relay activation.

For example, if Ch1A1 & Ch2A1 are selected in the AND column and Ch1A2 & Ch2A2 are selected in the OR column, the logic equation is [Ch1A1 AND Ch2A1] ANDED WITH [Ch1A2 OR Ch2A2]. This requires both A1’s along with either A2 to activate the relay.

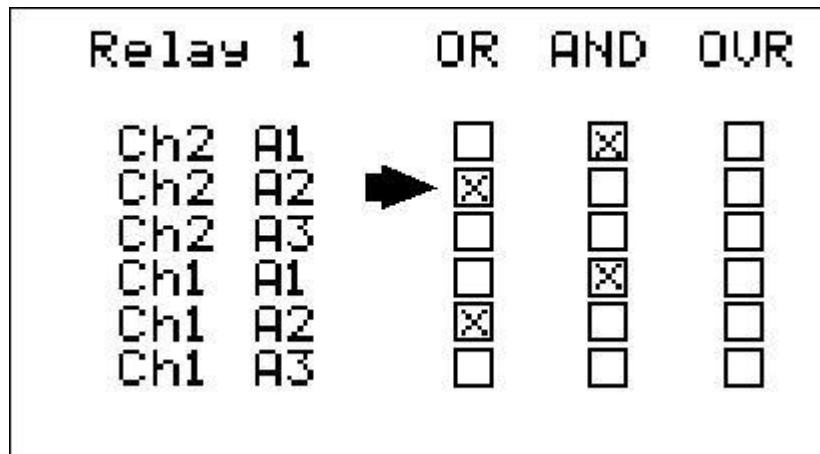

Figure 2.9

- **Failsafe** controls relay activation for the common relays. **Failsafe ON** causes these relays to de-energize during alarm conditions and energize when there is no alarm. With **Failsafe** active, a power failure forces the relay contact to the alarm position.
- **Horn** controls how activating this relay will affect the horn driver circuit connected to J2 on the motherboard. Choices are **NO**, **STEADY** or **PULSE**. Warning level alarms might be set to pulse the horn with high alarms set for steady. Personnel then know which alarm level is present by hearing the pulsing or steady horn.
- Turning **Acknowledge ON** (not allowed on Relay 1) allows Relay 2 to be deactivated during alarm conditions by an **Alarm Reset**. This is useful if another audible device is being driven by the relay. The acknowledge feature is not available for Relay 1 since it is often used for driving a warning light and Relay 2 for driving a horn. It could be dangerous if an operator acknowledged the horn AND the light since no indication of the high alarm condition remains.

2.3.2 HORN / PIEZO MENU

- The ST-90 display PCB is equipped with a small audible piezo that chirps when keys are pressed providing an audible feedback to the operator. It also may be set to audibly indicate alarm conditions by entering YES into the **Piezo On** menu item in Figure 2.10. This piezo will then mimic the **Horn** settings menus described in section 2.3.1.
- The **Horn ACK** menu item determines if the Horn Driver output may be acknowledged by an Alarm Reset. **YES** causes an Alarm Reset to silence the horn even though an alarm condition remains active.



Figure 2.10

2.3.3 COMM PORT MENU

The system **Comm Port** menu allows setting RTU address for the optional *slave* Modbus serial port. This slave port may be used to transfer ST-90 data to a host device such as a PC, PLC, DCS or even another R. C. Systems Controller. The slave port is addressable, allowing many ST-90 controllers to be connected to a single RS-485 cable.



Figure 2.11

2.3.4 CLOCK / DELAYS MENU

- The ST-90 monitors signals from sensors that may require varying times to stabilize after power is applied. The **Warm Up Delay** menu item allows setting how long alarm relays remain disabled after power is applied.
- **Cal Delay** determines how long alarm relays are inhibited after completing a calibration.
- The ST-90 is equipped with a 24-hour clock and calendar. **Time** and **Date** menu items are for setting the correct time and date. Time of day must be entered in 24 hour mode. For example, 6:00:00 PM = is indicated as 18:00:00.

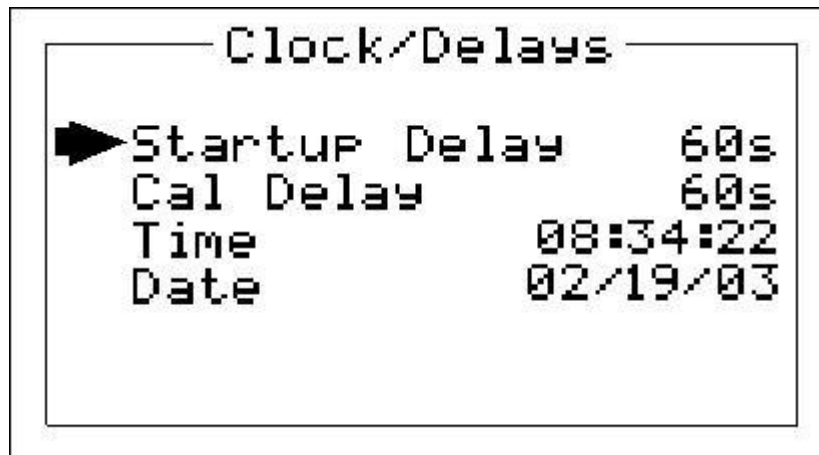

Figure 2.12

2.3.5 DIAGNOSTICS MENU

WARNING: Alarm processing is halted with the **Diagnostics** mode active.

The **Diagnostics** menu in Figure 2.13 is useful for testing standard and optional Input / Output devices such as relays and 4-20mA outputs. Diagnostic menu items are described below:

Discrete Relays menu item allows manual activation of the optional 10-0222 Discrete Relay boards.

2.4 SYSTEM SECURITY MENU

A 4-digit **Pass Code** entered and confirmed in this menu item locks all menus. *Viewing* menus is not denied but attempts to *edit* variables flashes the **Locked** message on the LCD.

Authorized individuals locking the system should first enter a name, phone #, or other contact information into the 12 character field on the top line of the Security screen. To lock or unlock the system the correct 4 digit authorization number must be entered into the **Pass Code** field. It is very important to remember the 4 digit code since the factory must be consulted if it is lost.

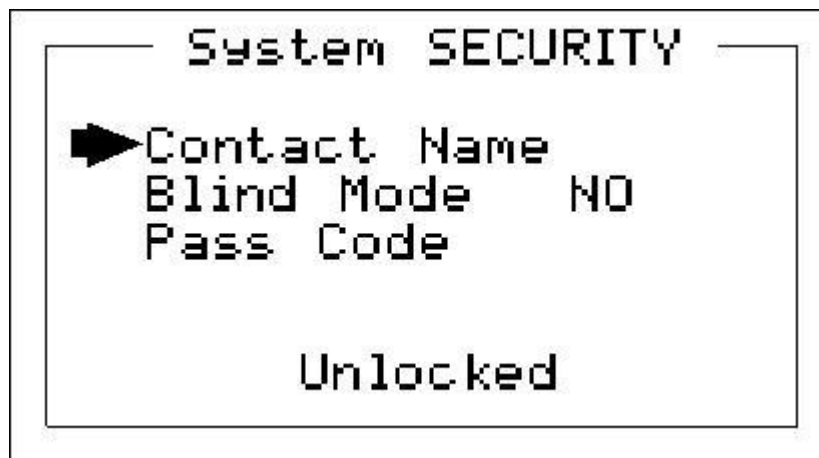

Figure 2.15

SECTION 3

3.0 MOTHERBOARD INTERFACE PCB # 10-0215

The ST-90 Motherboard shown below in Figure 3.1 is the interface between the Display / CPU assembly and all other system I/O devices. The Display / CPU assembly attaches to the motherboard with 4-standoffs and connects via ribbon cable to S1. Several input options, described in the following sections, are available that may be installed into the *Sensor Input Option* P1 connector located on the lower left side of the motherboard. The middle position P2 connector is for the 10-0223 4-20mA Output option and the right position P3 connector is for the 10-0222 Discrete Relay option. Other option devices such as Modbus RTU RS-485, Ethernet and a data logger may also be installed to connectors located on the Motherboard.

The Motherboard PCB contains a 24 VDC universal input (100-240 VAC) switching power supply with up to 350mA available at TB3 Auxiliary Power Output terminals. If AC power is unavailable, or if a DC battery back-up supply is needed, TB1 provides terminals for DC power input. Blocking diodes isolate internal and external DC supplies as shown in Figure 3.0. See section 1.2.1 for additional power source information.

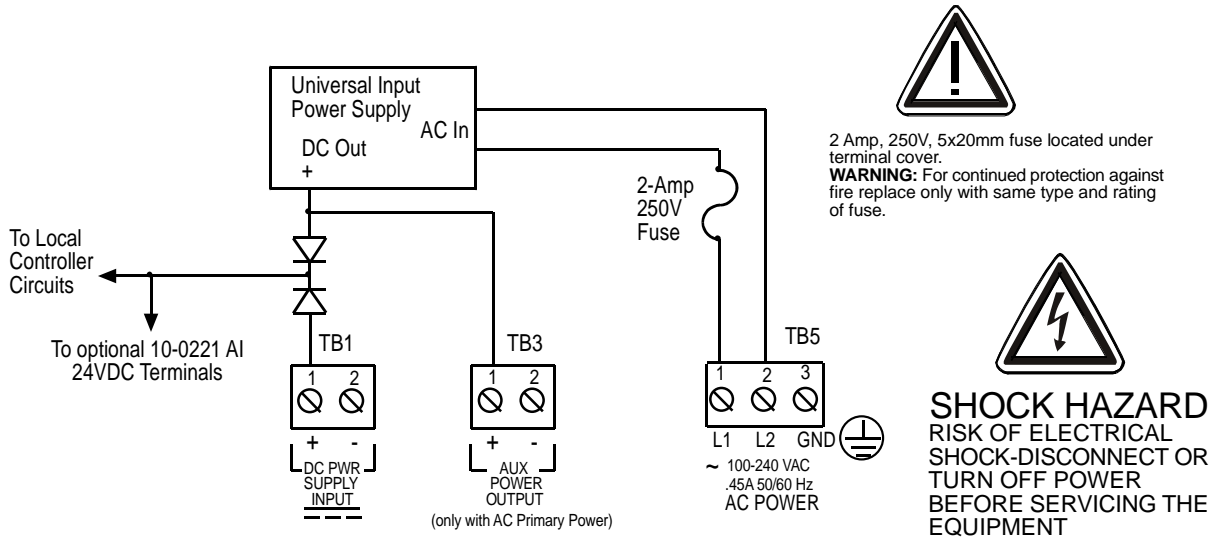

Figure 3.0

TB2 offers field terminals for a remote alarm reset switch. The motherboard also includes alarm relays 1 & 2 (K1 & K2) and their indicating LED's. TB4 provides field wiring terminals for these relays. TB5 is for connection to the 100-240 VAC power source. J2 is a 2-pin connector for powering the optional part # 1000-1892 audible annunciator.

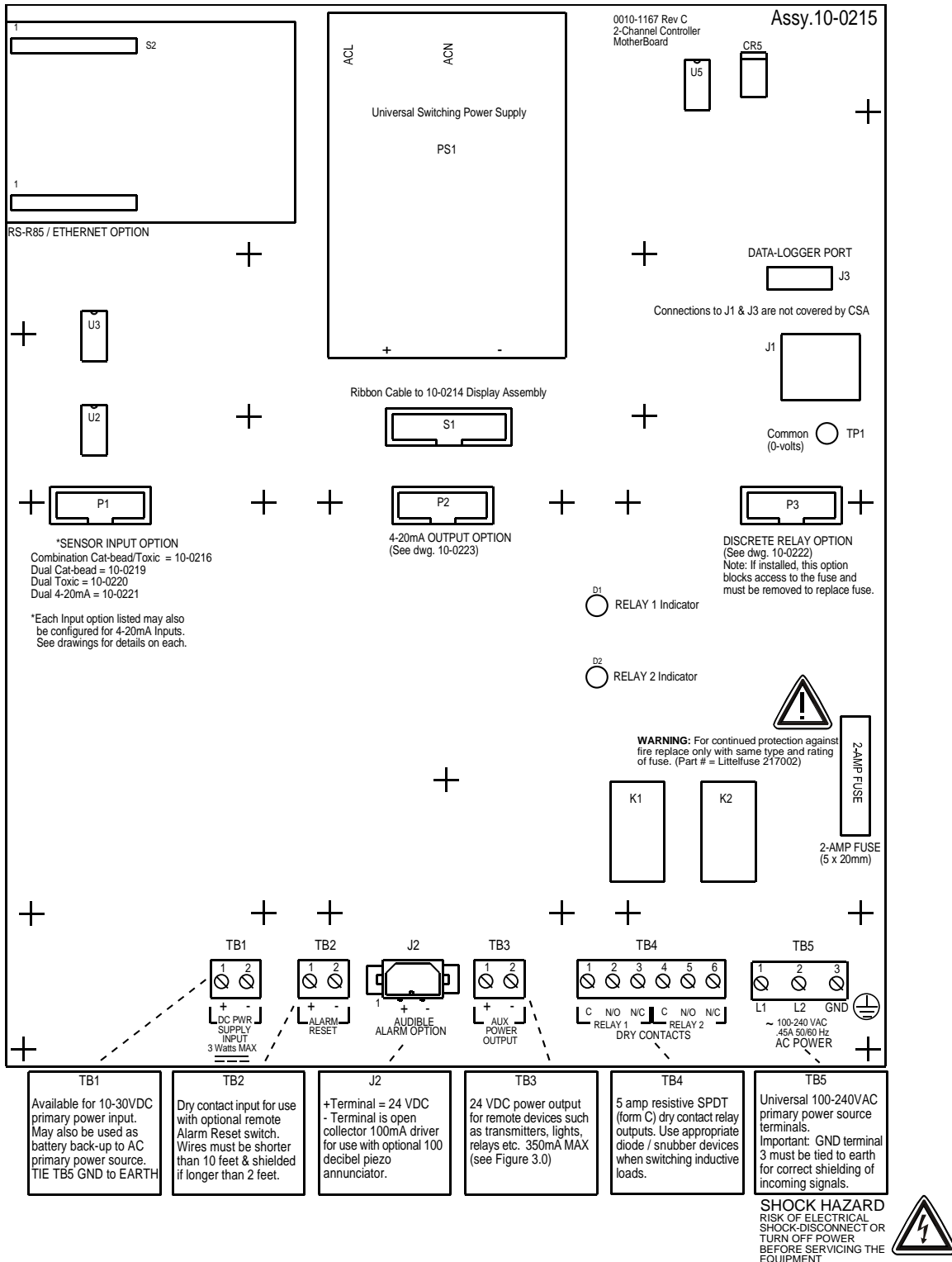

Figure 3.1

3.1 INPUT / OUTPUT OPTIONAL PCB's

P1, P2 and P3 connectors on the motherboard offer unique positions for I/O options described in this section. A screen appears briefly after power-up indicating what I/O options are connected. Input options installed into the P1 position may be either 10-bit or 12-bit and the **Input Min / Max** menu shown in Figure 2.14 must be set accordingly. The 10-0221-2 option's default setting is 400 – 2000 counts and the 10-0216, 10-0219 and 10-0220 each have a default setting of 200 – 1000 counts.

P2 is reserved only for the 10-0223 4-20mA Output option and P3 is reserved only for the 10-0222 Discrete Relay option. Connector locations, relative to each option's mounting screws, prevent incorrect installation.

3.1.1 OPTIONAL ANALOG INPUT PCB # 10-0221-2

Important! 10-0221-2 PCB's may only be installed into motherboard position P1.

12-bit Analog input PCB option # 10-0221-2, shown in Figure 3.2 allows interfacing ST-90's to field transmitters having 4-20mA or voltage outputs. Remove socketed 100 ohm R1 or R2 terminators for 0-4 VDC max voltage inputs. The 10-0221-2 utilizes a 12-bit A/D converter such that 4mA provides 400 counts and 20mA 2000 counts. Min/Max raw counts menus default to 400/2000 but may be adjusted between 0/4095 as described in the **Input Min / Max** discussion in section 2.3.5. TB1 provides Channel 1 & Channel 2 +/- terminals for receiving analog inputs. TB1 also provides 2-terminals connected to the ST-90 internal 24 VDC power supply for powering external transmitters. Figure 3.3 shows correct wiring for both 2-wire and 3-wire transmitters.

- *R1 = Ch1 100 ohm 4-20mA terminator
- *R2 = Ch2 100 ohm 4-20mA terminator
- *Spare = Spare 100 ohm 4-20mA terminator
- * These 3 resistors are socketed for easy replacement.
- Terminators are connected between each channel's HI & LO terminals.
- LO = 24VDC Power Supply Common
 24VDC = 24VDC Power Supply + output

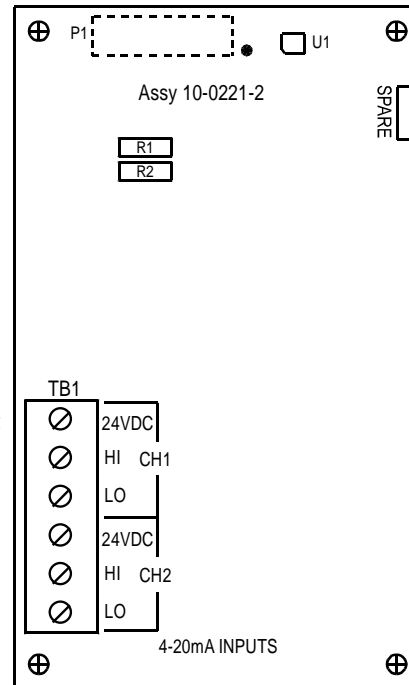

Figure 3.2

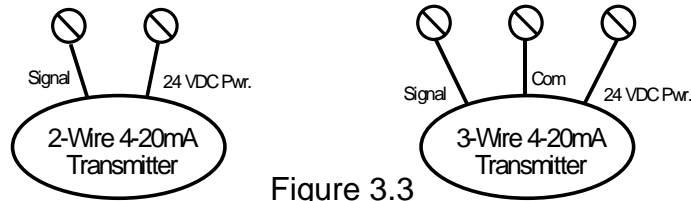

Figure 3.3

3.1.2 OPTIONAL BRIDGE / EC SENSOR INPUT BOARD #10-0216

Important! 10-0216 PCB's may only be installed into motherboard position P1.

The 10-bit 10-0216 Sensor input option shown in Figure 3.4 allows a bridge sensor into channel one and an electrochemical sensor into channel two. This combination is useful for monitoring volatile and toxic (or oxygen) gases at the same location. The bridge sensor channel includes bridge amplifier, balance potentiometer, and adjustable switching regulator for setting the correct sensor excitation voltage. A 3-position coarse gain jumper allows setting the gain of the bridge amplifier. Bridge sensors not mounted to the ST-90 enclosure at the factory will require the *Initial Setup* calibration procedure described in section 3.1.4. After performing the one time only *Initial Setup* all subsequent calibrations are by the ST-90's electronic Cal Mode menus (see section 2.2.5). Sensors mounted locally to the ST-90 normally do not require *Initial Setup* since it is performed at the factory.

The electrochemical channel has a preamplifier, bridge amplifier, sensor coefficient jumpers and a 2-position coarse gain jumper for setting the gain of the bridge amplifier. Socketed resistor R11 controls the gain of the preamplifier and is installed at the factory (consult factory if sensor gas type is to be changed after shipment). Fault supervision circuitry forces the ST-90 into a FAULT condition upon sensor failure or removal.

The 10-0216 may also be configured to accept 4-20mA inputs for mixing a direct sensor input and a current loop into the same board. Placing either channel's 2 position SENSOR/4-20mA jumper (JP4 or JP5) into the 4-20mA position, and installing the associated precision 100 ohm socketed resistor, allows 4-20mA signals to be applied to the mA+ / mA- terminals (see *Optional 4-20mA notes* in Figure 3.4). 100 ohm resistors are taped to the inside of the ST-90 enclosure. Bridge amplifiers are bypassed in this configuration. Figure 3.4 shows jumper options with channel 1 configured for a 4-20mA input and channel 2 for a sensor input.

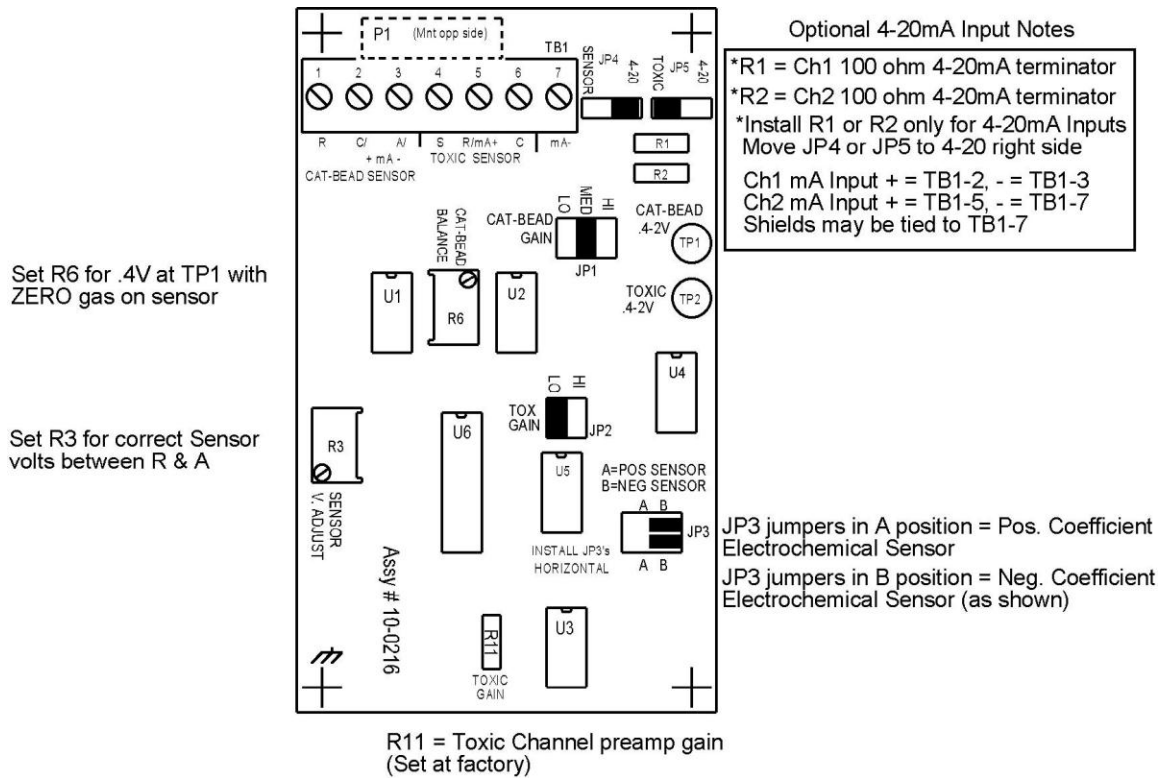

Figure 3.4

3.1.3 OPTIONAL BRIDGE SENSOR INPUT BOARD #10-0219

Important! 10-0219 PCB's may only be installed into motherboard position P1.

The 10-bit 10-0219 Two Channel *Bridge Sensor Input* option shown in Figure 3.5 allows these popular gas detectors to be connected directly to the ST-90 without additional signal conditioning or transmitters. Each channel is equipped with a bridge amplifier, balance potentiometer, and an adjustable switching regulator for setting the correct sensor excitation voltage. A 3 position coarse gain jumper allows setting the gain of the bridge amplifier. Fault supervision circuitry forces the ST-90 into a FAULT condition upon sensor failure or removal.

This option may also be configured to accept 4-20mA inputs for mixing a sensor and a current loop into the same board. Placing either channel's 2 position SENSOR/4-20mA jumper (JP3 or JP4) into the 4-20mA position, and installing the associated precision 100 ohm socketed resistor, allows 4-20mA signals to be applied to the mA+ / mA- terminals (see *Optional 4-20mA notes* in Figure 3.5). 100 ohm resistors are taped to the inside of the ST-90 enclosure.

Bridge sensors not mounted to the ST-90 enclosure at the factory will require the *Initial Setup* calibration procedure described in section 3.1.4. After performing the one time only *Initial Setup* all subsequent calibrations are by the ST-90's electronic Cal Mode menus (see section 2.2.5). Sensors mounted locally to the ST-90 normally do not require *Initial Setup* since it is performed at the factory.

3.1.4 BRIDGE SENSOR INITIAL SETUP

Bridge sensors vary widely in power requirements and sensitivity. It is therefore important to configure each channel to match the sensor with which it will operate.

Sensors attached to the ST-90 enclosure at the factory have already had *Initial Setup*.

1. Prior to connecting remote sensors, apply power to the system. Measure the voltage between each channel's A and R terminals and set the *Voltage Adjust* potentiometers for the correct sensor excitation voltage (remove ST-90 terminal cover). This may range from 1.5 volts to 7.5 volts depending upon sensor specifications. **Sensors may be damaged by accidental over voltage conditions. It is recommended the *Voltage Adjust* potentiometer screws be covered by a dollop of RTV or similar material after completion of this procedure.**
2. Remove system power and connect sensor wires to the A-C-R terminals. Reapply system power and confirm correct voltage across each sensor's A & R terminals. Note if sensor wires are long, it will be necessary to measure the excitation voltage at the sensor end to compensate for $I * R$ voltage losses in the wiring.
3. With the minus voltmeter lead on TB2-2 (common), connect the plus lead to the channel's red test point. With zero air on that sensor, adjust its *Balance* potentiometer for .4 volts at the test point.
4. Apply 50% span gas to the sensor and allow the test point voltage to stabilize. Two volts = 100% input to the A – D Converter and .4 volts = 0%. Therefore, 1.2 volts = 50%. Place the 3 position *Coarse Gain* jumper into the position which reads between 1.1 volts and 1.4 volts on the test point with 50% gas on the sensor. Gain settings for each jumper position are as follows: no jumper = 1, **LO** = 7, **MED** = 12, **HI** = 24. Multiple jumpers have an additive affect upon gain, so for example the **LO** and **MED** jumpers together provide a gain of 19.

Initial setup is now complete and normally only requires repeating if a sensor is replaced. Final calibration of this channel may now be performed using the ST-90's electronic Cal Mode feature described in section 2.2.5.

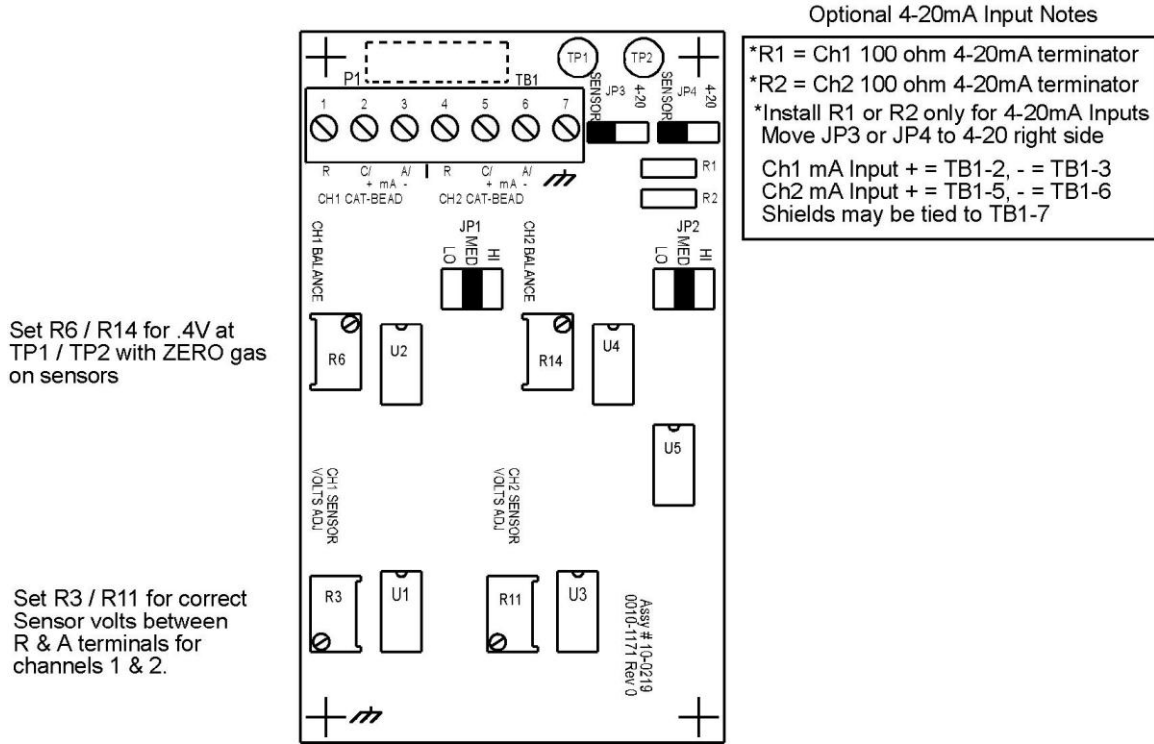

Figure 3.5

3.1.5 OPTIONAL ELECTROCHEMICAL SENSOR INPUT BOARD #10-0220

Important! 10-0220 PCB's may only be installed into motherboard position P1.

The 10-bit 10-0220 Two Channel *Electrochemical Sensor Input* option shown in Figure 3.6 allows these popular gas sensors to be connected directly to the ST-90 without additional signal conditioning or transmitters. Each channel is equipped with a preamplifier, bridge amplifier, sensor coefficient jumpers and a 2 position coarse gain jumper for setting the gain of the bridge amplifier. Socketed resistors R4 and R16 control the gain of the preamplifier and are installed at the factory (consult factory if sensor gas type is to be changed after shipment). Fault supervision circuitry forces the ST-90 into a FAULT condition upon sensor failure or removal.

This option may also be configured to accept 4-20mA inputs for mixing an electrochemical sensor and a current loop into the same board. Placing any channel's 2 position TOXIC/4-20mA jumper into 4-20mA position and installing the associated precision 100 ohm socketed resistor allows 4-20mA signals to be applied to it's mA + / mA - terminals. Bridge amplifiers are bypassed in this configuration.

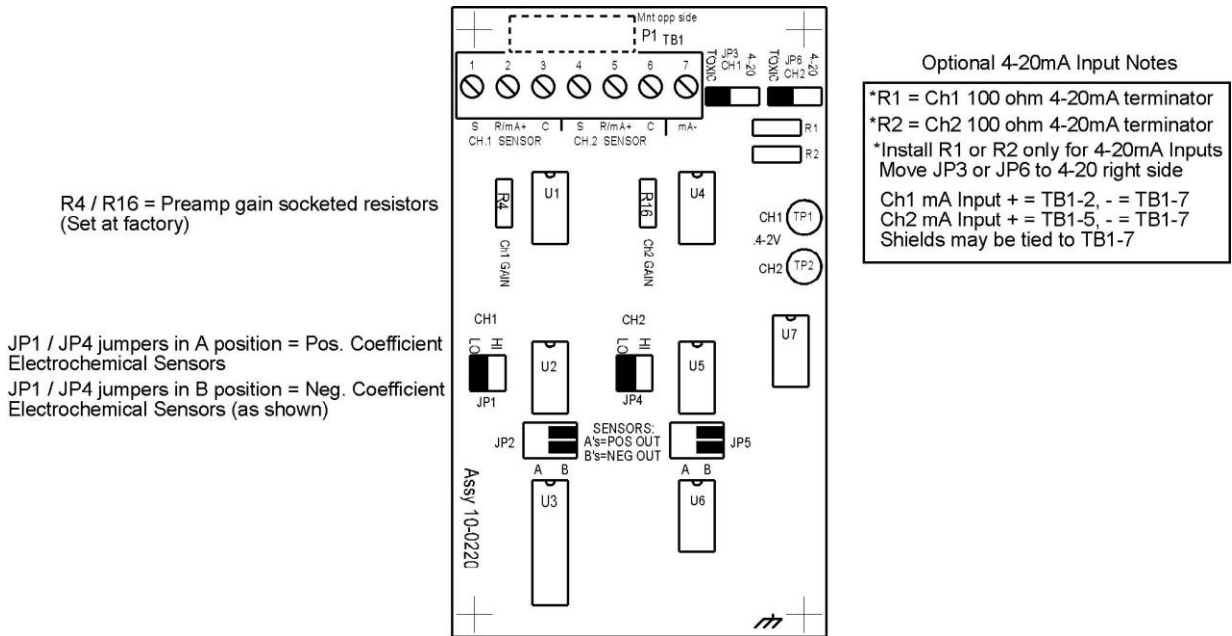

Figure 3.6

3.1.6 OPTIONAL DISCRETE RELAY PCB's #'s 10-0222

Important! 10-0222 PCB's may only be installed into motherboard position P3.

The optional *Discrete Relay PCB*, shown in Figure 3.7, adds six 5 amp form C relays. Each relay is associated to one of A1, A2 or A3 for channel 1 or 2. Many ST-90 applications utilize the standard equipped Relay 1 / Relay 2 (see section 2.3.1) and do not require optional discrete relays for each of the 6 alarms events (2 A1's, 2 A2's & 2 A3's).

All mechanical (dry contact) relays are rated at 5 Amp for 28 VDC and 250 ~VAC **RESISTIVE** loads. **IMPORTANT:** Appropriate diode (DC loads) or MOV (AC loads) snubber devices must be installed with inductive loads to prevent RFI noise spikes.



AC or DC power supplies to relays on the 10-0222 Discrete Relay PCB option must be the same for each relay. Example: 24VDC should not be the power switched by one relay and 115VAC by others.

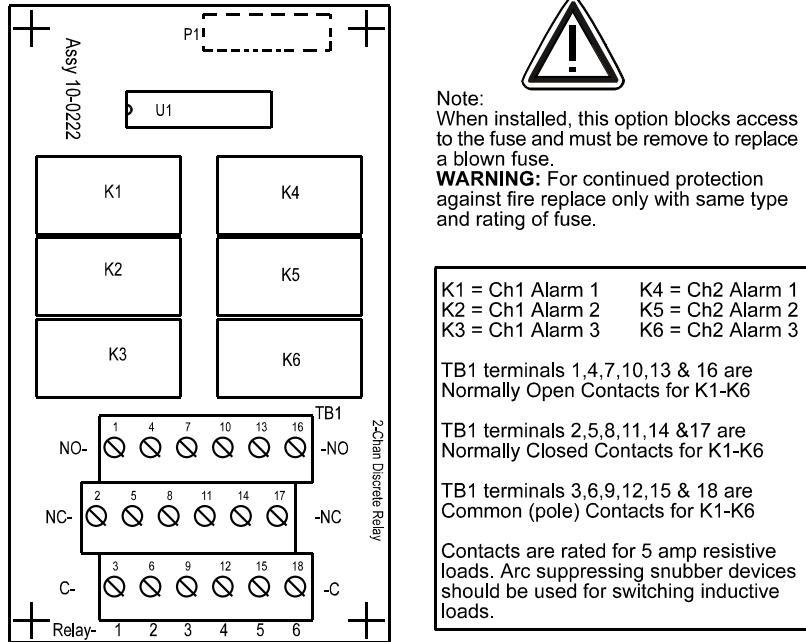

Figure 3.7

3.1.7 OPTIONAL 4-20mA ANALOG OUTPUT BOARD #10-0223

Important! 10-0223 PCB's may only be installed into motherboard position P2.

An optional 10-bit 4-20mA analog output board, shown in Figure 3.8, may be added. Each channel's output will transmit 4mA for 0% readings and 20mA for 100% readings. If the ST-90 primary power is 100 – 240 VAC or at least 24 VDC, 4-20mA outputs are capable of driving 20mA through a 750 ohm load. Outputs are self powered and DC power should not be provided by the receiving device. Precision calibration of the 4-20mA output DAC (digital to analog converter) is accomplished via the **Diagnostics** menu as described in section 2.3.5.

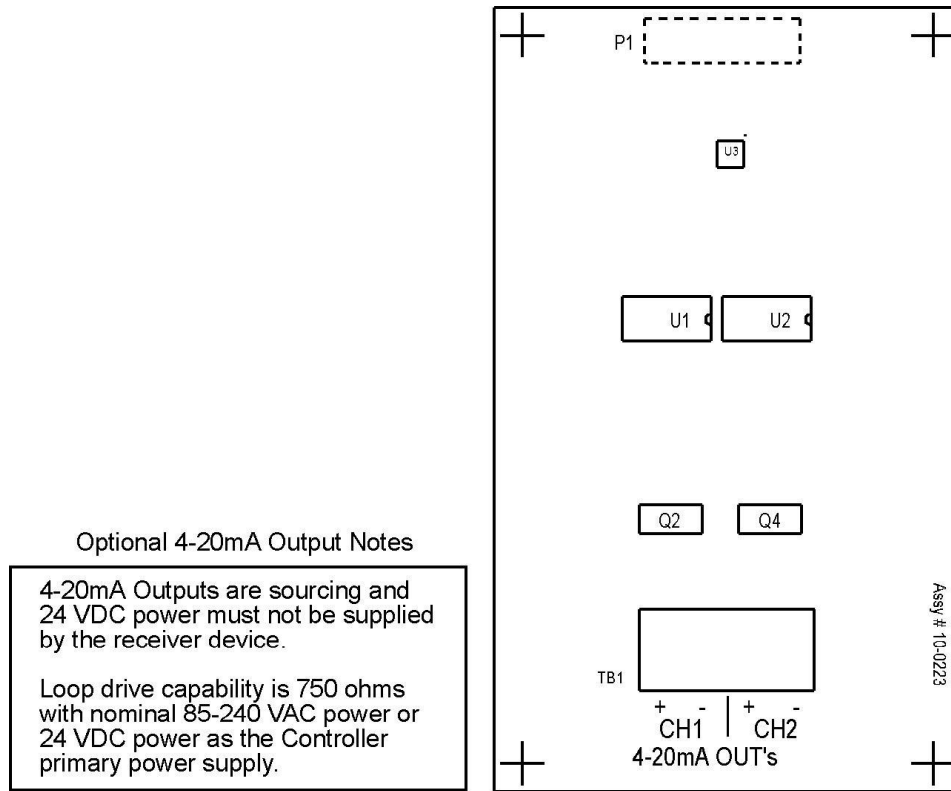

Figure 3.8

3.2 MODBUS RS-232 / RS-485 INTERFACE OPTION 10-0253

The 10-0253 Modbus option PCB add both RS-232 and RS-485 Modbus RTU slave ports. Figure 3.9 shows this optional PCB which mounts to connectors on the upper right corner of the ST-90 motherboard. TB1 provides two pairs of T/Rx terminals and a floating terminal for shield continuation. This makes it easy to multi-drop ST-90's onto an RS-485 cable without doubling wires into the same screw terminals. RS-232 interface may be made by connecting to DB9 connector S1. Section 3.2.1 lists all modbus registers and their function codes.



Follow correct IEEE RS-232 and RS-485 installation guidelines when using the 10-0253 option.



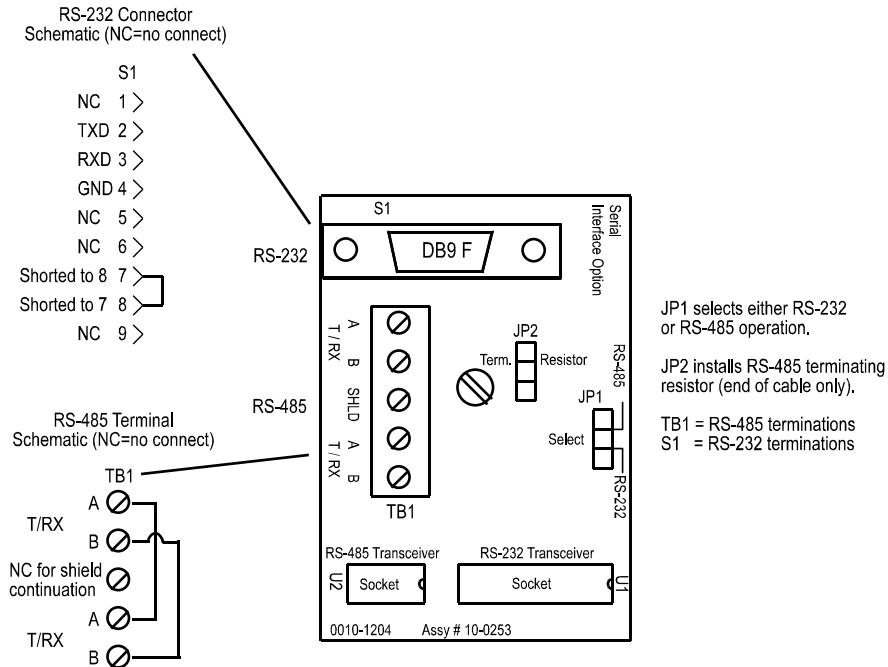

Figure 3.9

3.2.1 MODBUS REGISTER AND FUNCTION CODE SUMMARY

The following table identifies ST-90 Modbus register locations and function codes.

VARIABLE	ALIAS	READ FUNCTION CODE	WRITE FUNCTION CODE
----------	-------	--------------------	---------------------

Read/Write Coils:

Alarm Ack/Reset	2001	1	5
-----------------	------	---	---

Note: After writing a TRUE to this register, the ST-90 will reset it to FALSE.

Read Only Discrete:

Chan 1	Alarm 1	12001	2	NA
Chan 1	Alarm 2	12002	2	NA
Chan 1	Alarm 3/Flt	12003	2	NA
Chan 2	Alarm 1	12004	2	NA
Chan 2	Alarm 2	12005	2	NA
Chan 2	Alarm 3 /Flt	12006	2	NA
Relay 1		12007	2	NA
Relay 2		12008	2	NA

Read Only Registers:

Product ID 30001 4 NA
 Returns the numeric value 90 for product ID.

Firmware value 30002 4 NA
 Return a numeric value for firmware value as (Version X 100).

D2A Chan 1 31001 4 NA
 D2A Chan 2 31002 4 NA
 10 bit value representing the D2A value of 0 to 1023 after all cal features are applied.

A2D Raw Chan 1	31003	4	NA
A2D Raw Chan 2	31004	4	NA

10 bit value representing the A2D value of 0 to 1023 for -25 to 103 %FS (197=0% & 1003=100%).

Chan 1 Status	31005	4	NA
Chan 2 Status	31006	4	NA

16 bit status word bit assignment for each channel.

ALARM1_BELOW_BIT	BIT0
ALARM2_BELOW_BIT	BIT1
ALARM3_BELOW_BIT	BIT2
ALARM1_LATCH_BIT	BIT3
ALARM2_LATCH_BIT	BIT4
ALARM3_LATCH_BIT	BIT5
ALARM3_ACTIVE_BIT	BIT6
CHANNEL_DISABLED_BIT	BIT7
CHANNEL_CAL_BIT	BIT8

System Status Word	31007	4	NA
--------------------	-------	---	----

16 bit status word bit assignment for system status.

PIEZO_DRIVE	BIT6
HORN_ACK	BIT7
K1_HORN_DRIVE	BIT8
K2_HORN_DRIVE	BIT9
K1_HORN_PULSE	BIT10
K2_HORN_PULSE	BIT11
K1_FAILSAFE	BIT12
K2_FAILSAFE	BIT13
K2_ACK	BIT14
LOCK	BIT15

Alarm Status Word	31008	4	NA
-------------------	-------	---	----

16 bit status word bit assignment for system status.

CHAN_1ALM_1	BIT0
CHAN_1ALM_2	BIT1
CHAN_1ALM_3	BIT2
CHAN_2ALM_1	BIT3
CHAN_2ALM_2	BIT4
CHAN_2ALM_3	BIT5
RELAY_1	BIT6
RELAY_2	BIT7
PIEZO	BIT7

SENSOR_LIFE Chan1	31009	4	NA
SENSOR_LIFE Chan2	31010	4	NA

Returns -1 for "Cal Required" status or 0 to 100 for Sensor Life.

LED Blink Status	31011	4	NA
------------------	-------	---	----

Bit set to 1 = LED Blinking, bit set to 0 = LED Not blinking.

CHAN1_ALM1	BIT0
CHAN1_ALM2	BIT1
CHAN1_ALM3	BIT2
CHAN2_ALM1	BIT3
CHAN2_ALM2	BIT4
CHAN2_ALM3	BIT5

Disc Relay Status	31012	4	NA
-------------------	-------	---	----

16 bit status word bit assignment for system status.

CHAN_1ALM_1	BIT0
CHAN_1ALM_2	BIT1
CHAN_1ALM_3	BIT2
CHAN_2ALM_1	BIT3
CHAN_2ALM_2	BIT4
CHAN_2ALM_3	BIT5

RELAY_1	BIT6
RELAY_2	BIT7
PIEZO	BIT7

Memory Floating Point:

Notes: Returned as 15 bit 2s complement with +- 5% over/underrange applied.. Therefore this must be considered when scaling values to be displayed at the Workstation. The following equation may be used to determine a value for display.

$$\text{Display Value} = \frac{\text{MODBUS Value} \cdot [(\text{Span Value} - \text{Zero Value}) \cdot 1.1]}{32767} + \{ \text{Zero Value} - [(\text{Span Value} - \text{Zero Value}) \cdot 0.05] \}$$

FP Value Chan 1	33001	4	NA
FP Value Chan 2	33002	4	NA

Memory Reals:

Notes: Real value represents float value without the decimal point such as 123.4 is returned as 1234. Decimal divisor is returned as 1, 10, 100, or 1000 for decimal position of 1, 2, 3, or 4, where 123.4 would return the value 10.

Chan 1 Zero Real	41001	3	NA
Chan 1 Zero Devisor	41002	3	NA
Chan 1 Span Real	41003	3	NA
Chan 1 Span Devisor	41004	3	NA
Chan 1 Alarm 1 Real	41005	3	NA
Chan 1 Alarm 1 Devisor	41006	3	NA
Chan 1 Alarm 2 Real	41007	3	NA
Chan 1 Alarm 2 Devisor	41008	3	NA
Chan 1 Alarm 3 Real	41009	3	NA
Chan 1 Alarm 3 Devisor	41010	3	NA
Chan 2 Zero Real	41011	3	NA
Chan 2 Zero Devisor	41012	3	NA
Chan 2 Span Real	41013	3	NA
Chan 2 Span Devisor	41014	3	NA
Chan 2 Alarm 1 Real	41015	3	NA
Chan 2 Alarm 1 Devisor	41016	3	NA
Chan 2 Alarm 2 Real	41017	3	NA
Chan 2 Alarm 2 Devisor	41018	3	NA
Chan 2 Alarm 3 Real	41019	3	NA
Chan 2 Alarm 3 Devisor	41020	3	NA

Binary Cal Data:

Chan 1 A2D MIN	41021	3	NA
Chan 1 A2D MAX	41022	3	NA
Chan 1 D2A MIN	41023	3	NA
Chan 1 D2A MAX	41024	3	NA
Chan 2 A2D MIN	41025	3	NA
Chan 2 A2D MAX	41026	3	NA
Chan 2 D2A MIN	41027	3	NA
Chan 2 D2A MAX	41028	3	NA

Min and Max calibration points for the A/D and D/A converters.

Memory ASCII Strings:

User Info Chan 1	40401-40405	3	NA
User Info Chan 2	40406-40410	3	NA

10 ASCII characters (2 per register) assigned to the unit identifier read as bytes.

EUNITS Chan 1	40411-40415	3	NA
EUNITS Chan 2	40416-40420	3	NA

10 ASCII characters (2 per register) assigned to the engineering units read as bytes.

Chan 1 ASCII Reading	40421-40423	3	NA
Chan 2 ASCII Reading	40424-40426	3	NA

6 ASCII characters (2 per register) reflecting the display readout..

Firmware Version:

Version	40427-40428	3	NA
3	ASCII characters (2 per register) reflecting the firmware version.		

3.3 OPTIONAL EXTERNAL 24VDC 50 WATT POWER SUPPLIES

Some applications may require 24VDC power in excess of the 12 watts supplied by the ST-90. NEC Class 2 FIFTY WATT external supplies are available for Division 1 (part # 10-0314) and Division 2 (part # 10-0315) potentially hazardous area installations and both also include a NEMA 4X weather rating. See complete specifications at: http://www.rcsystemsco.com/rc/prod_view.asp?pid=25.

SECTION 4

4.0 ST-90N4 NEMA 4X WALL MOUNT ENCLOSURE

The ST-90/DUAL/N4 wall mount NEMA 4X enclosure is shown in Figure 4.0. Non-metallic enclosures are not grounded by metal conduit. For internal ground points to be grounded to earth, the TB5 – GND terminal must have a proper earth ground connection (see Figure 3.1).



CAUTION: NONMETALLIC ENCLOSURE DOES NOT PROVIDE GROUNDING BETWEEN CONDUIT CONNECTIONS. USE GROUNDING TYPE BUSHINGS AND JUMPER WIRES. ALL FIELD WIRING MUST HAVE INSULATION SUITABLE FOR AT LEAST 250V.



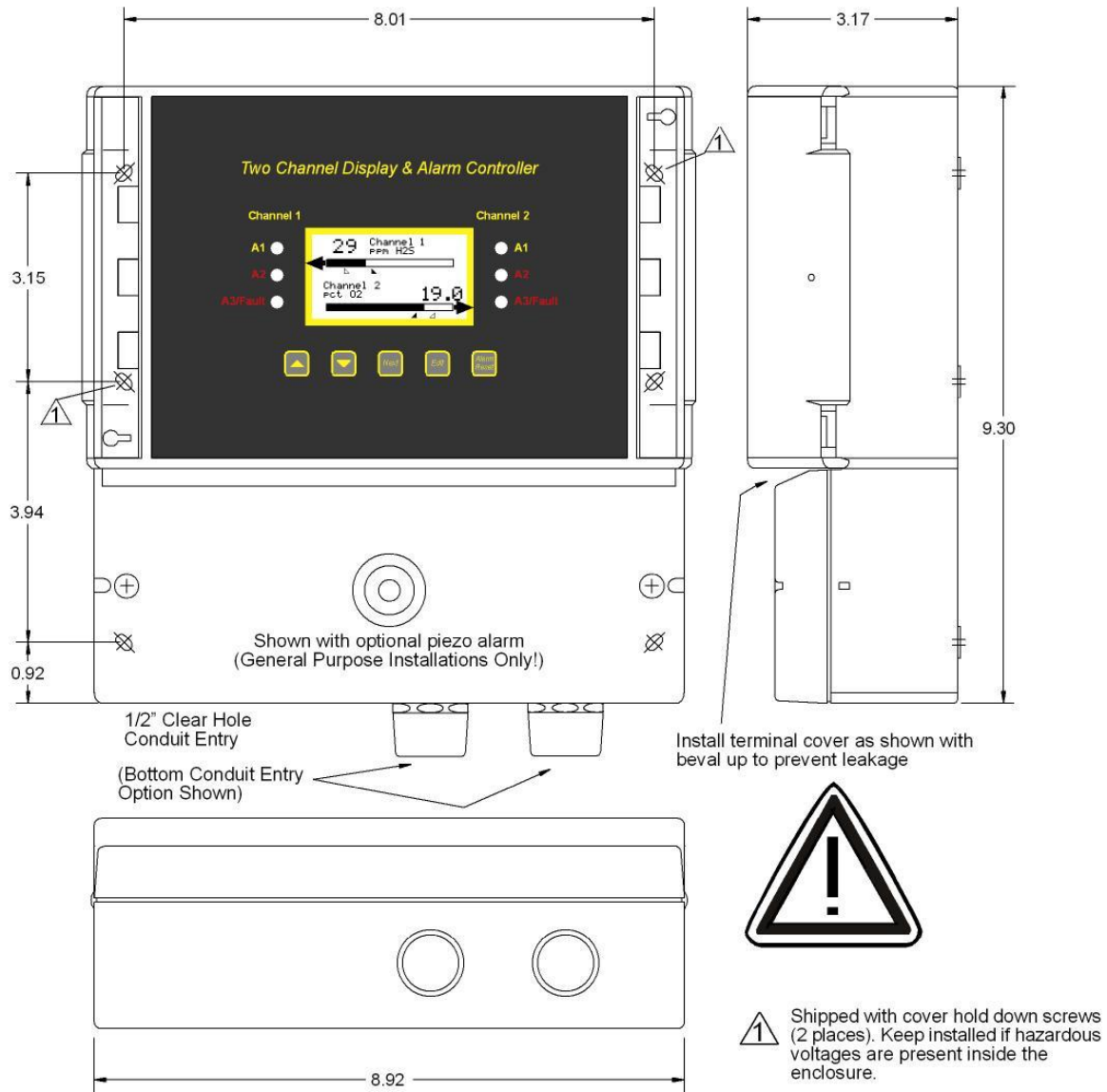

Figure 4.0

4.1 ST-90XP NEMA 7 EXPLOSION-PROOF WALL MOUNT ENCLOSURE

The ST-90DUAL/XP shown in Figure 4.1 is an aluminum NEMA 7 wall mount enclosure designed for mounting into potentially hazardous.

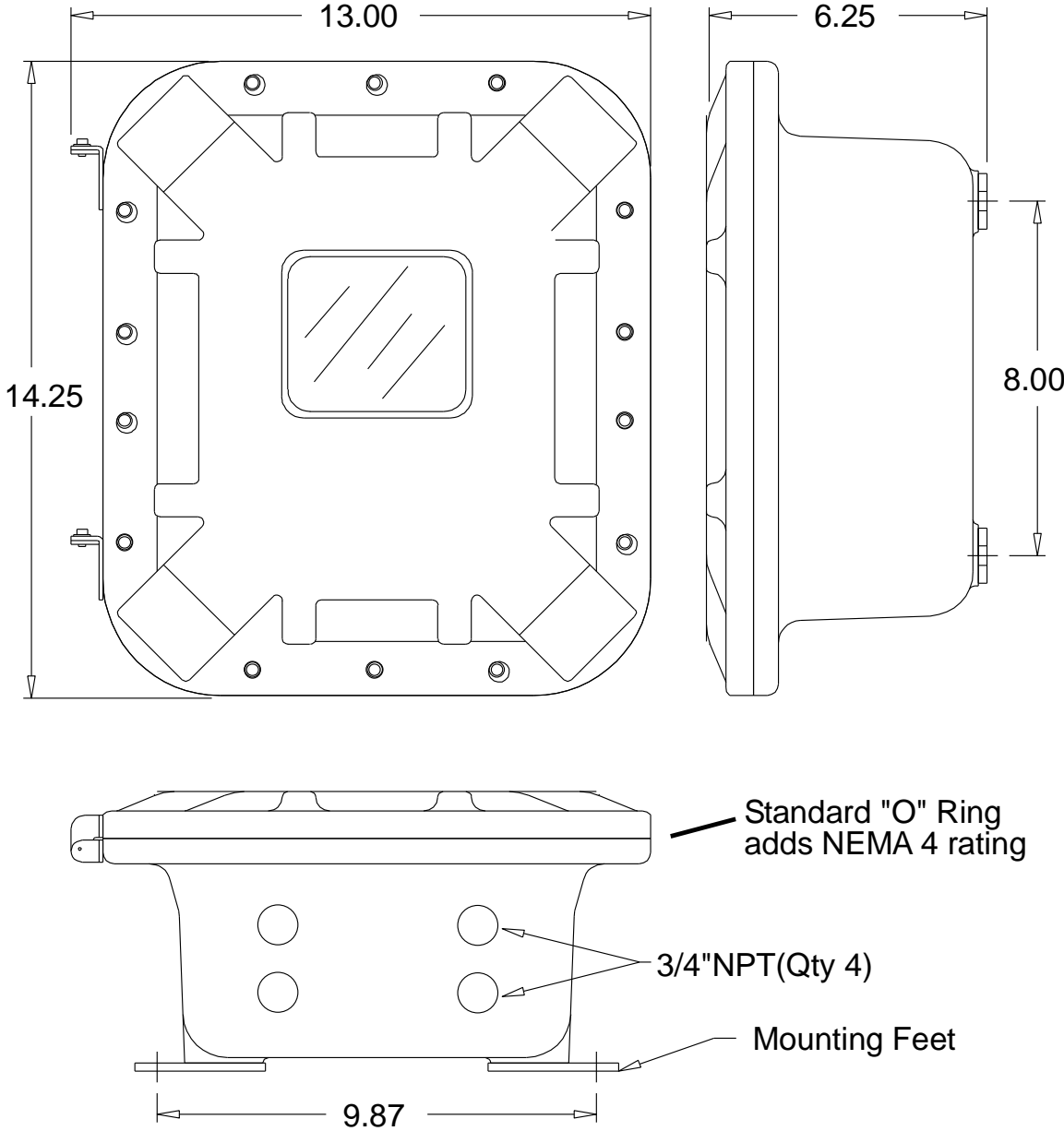

Figure 4.1

4.2 ST-90PY NEMA 4X POLYCARBONATE WALL MOUNT ENCLOSURE

The ST-90/DUAL/PY wall mount NEMA 4X enclosure is shown in Figure 4.2. Non-metallic enclosures are not grounded by metal conduit. For internal ground points to be

grounded to earth, the TB5 – GND terminal must have a proper earth ground connection (see Figure 3.1).



CAUTION: NONMETALLIC ENCLOSURE DOES NOT PROVIDE GROUNDING BETWEEN CONDUIT CONNECTIONS. USE GROUNDING TYPE BUSHINGS AND JUMPER WIRES. ALL FIELD WIRING MUST HAVE INSULATION SUITABLE FOR AT LEAST 250V.

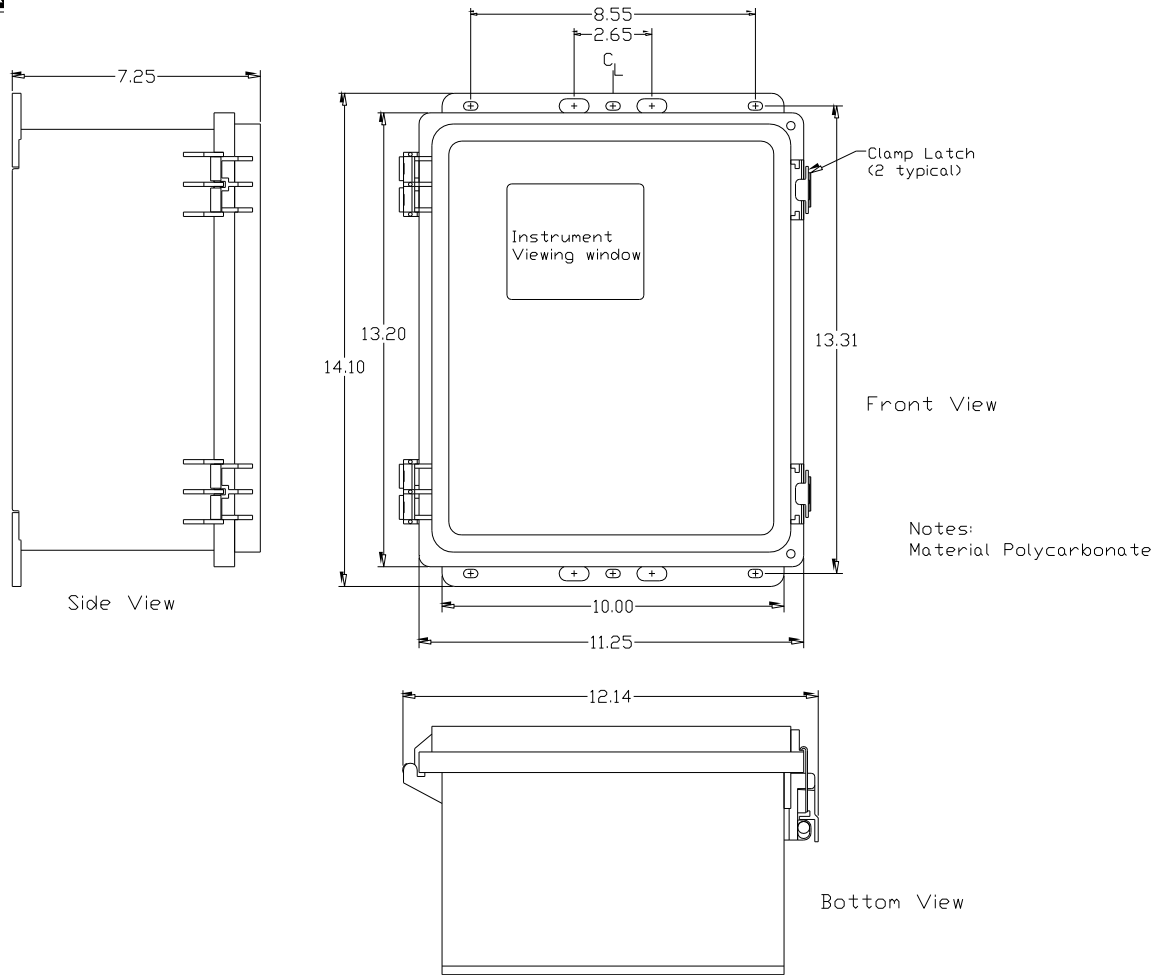

Figure 4.2

4.3 ST-90PCS NEMA 4 PAINTED STEEL WALL MOUNT ENCLOSURE

The ST-90DUAL/PCS shown in Figure 4.3 is a Painted Carbon Steel NEMA 4 wall mount enclosure designed for non-corrosive installations.

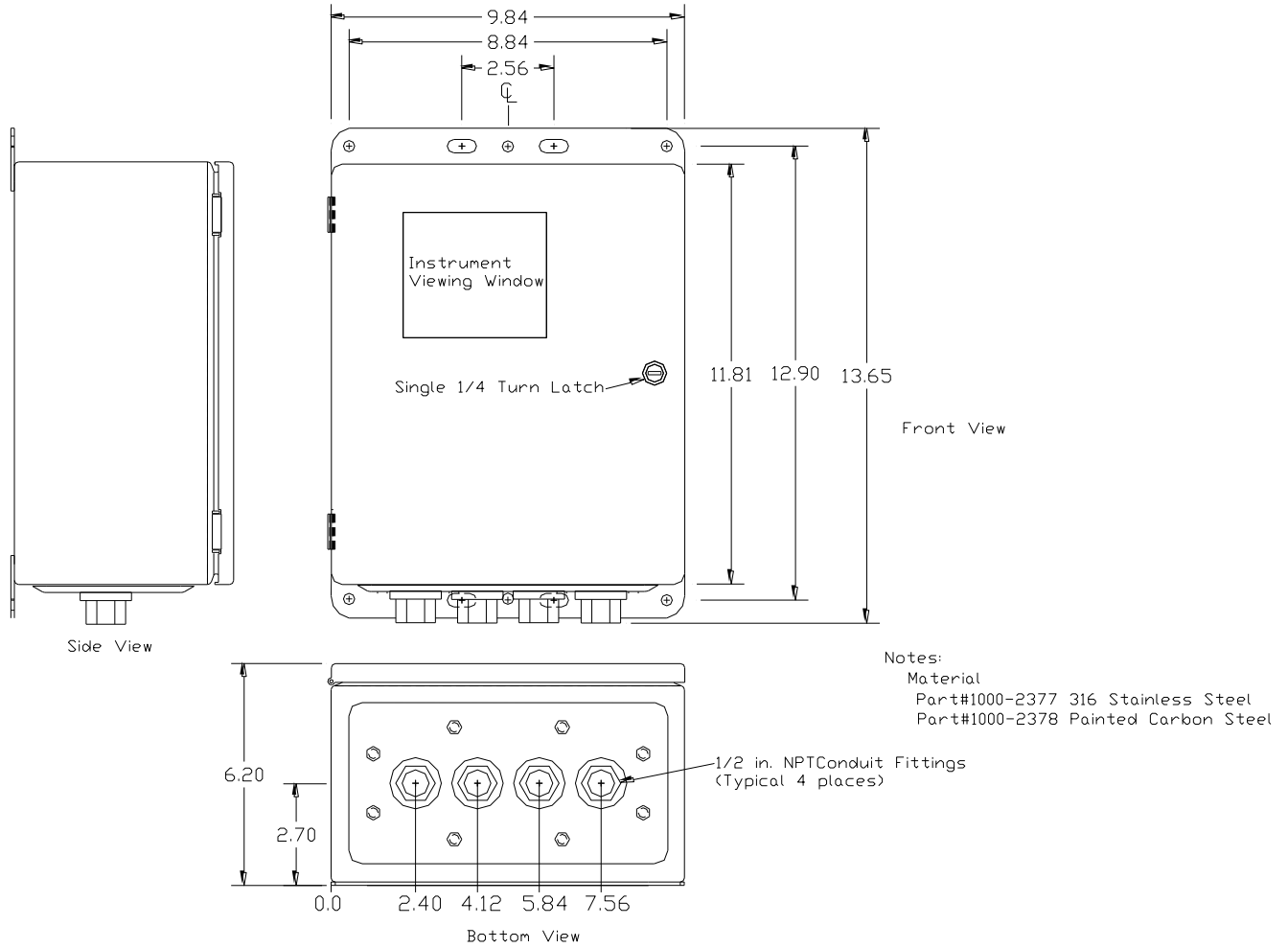

Figure 4.3

4.4 ST-90SS NEMA 4X STAINLESS STEEL WALL MOUNT ENCLOSURE

The ST-90DUAL/SS shown in Figure 4.4 is a 316 Stainless Steel NEMA 4X wall mount enclosure designed for corrosive installations.

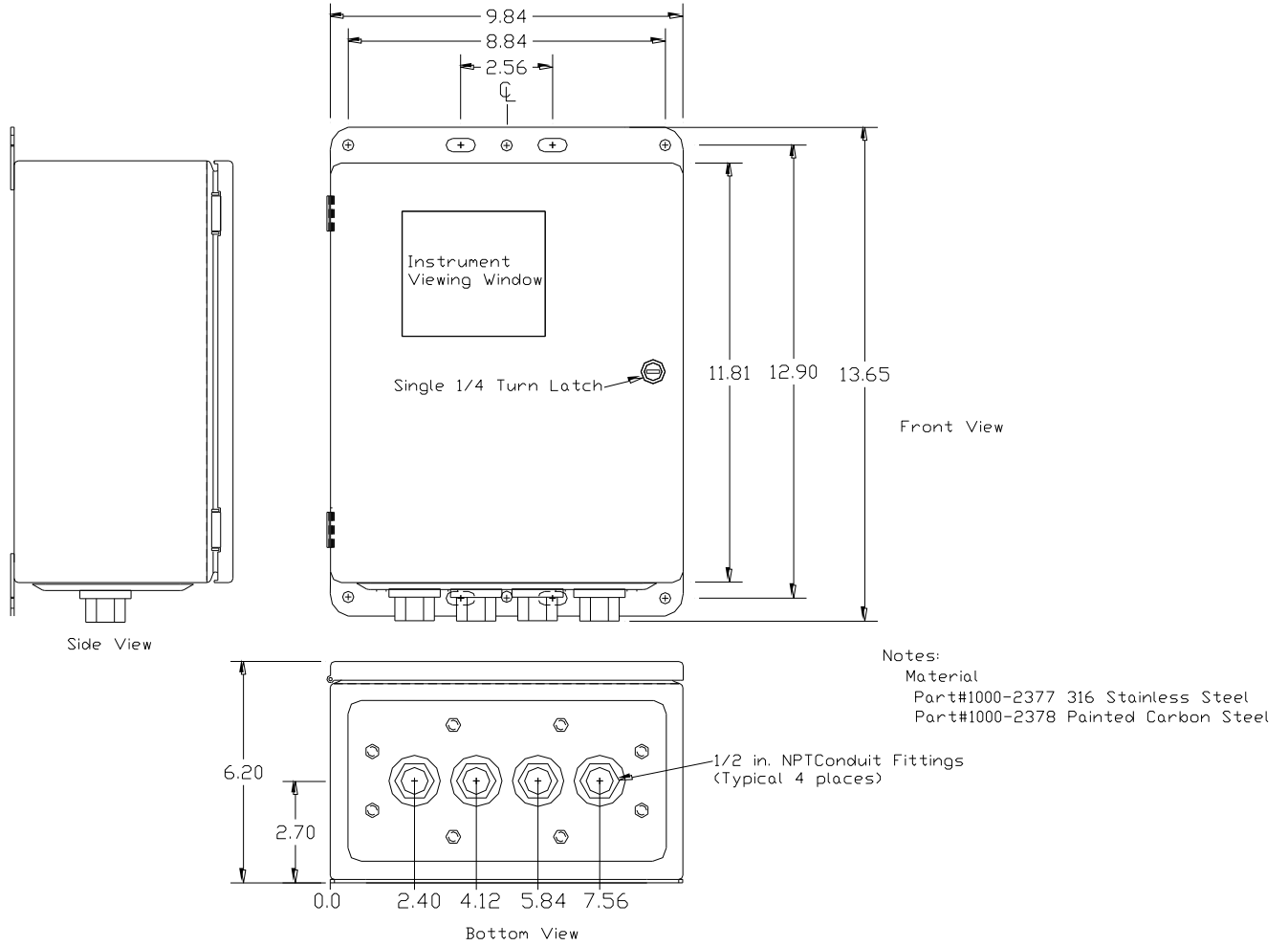

Figure 4.4