

FEATURES:

- Field replaceable toxic / oxygen sensor module.
- Range & target gas configured on sensor module.
- Improves system noise immunity because low level sensor signals are protected within the stainless steel sensor head.
- Industry standard 4-20mA signal may be transmitted thousands of feet on 2-wires.
- Suitable for Division 1 & 2 hazardous areas. May be installed as an intrinsically safe device with a barrier, or, explosion-proof for NEMA 7 installations.
- Missing sensor forces <2mA FAULT indication.
- Designed for use with our 1, 2, 4, 16 or 64 channel Controllers. Calibration is not possible at the ST-49 and may only be performed at the 4-20mA receiver!
- 2-wire 4-20mA signal is nonpolar with protective “steering diode” interface.
- Standard "Fault Supervision" circuitry continuously monitors for failed sensor. 4-20mA output transmits <2mA during failures.

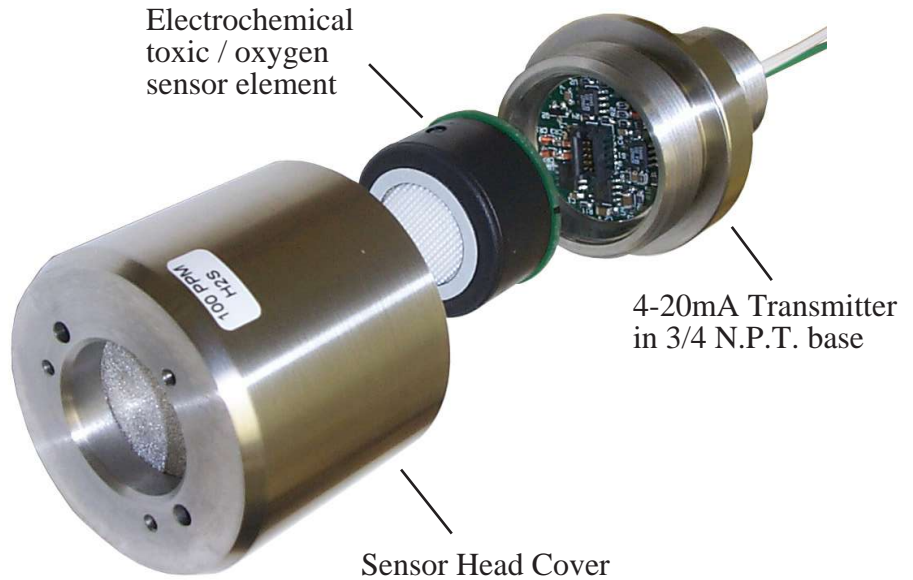

The R. C. Systems Co. Inc. Model ST-49 is a 2-wire 4-20mA Sensor Transmitter . It accepts low power toxic or oxygen electrochemical sensor modules and functions in a 2-wire 4-20mA “sink” mode to transmit gas values to an appropriate receiver device. The ST-49 overcomes noise immunity problems associated with electrochemical sensors by enclosing all low level signals within a grounded metallic sensor head. Target gas type and range are determined by the field replaceable sensor module.

Calibration and / or validation of monitored gas values must be performed at the receiver device. R. C. Systems Inc. offers single, dual, four, 16, and 64 channel receivers suitable for calibration, display, alarm and transmission of monitored gas values.

The ST-49 is enclosed in a rugged stainless steel or aluminum (10-0248IS) enclosure suitable for installation into potentially hazardous environments. It is intrinsically safe (IS) with an approved IS barrier, or explosion-proof in NEMA 7 installations. An optional junction box is available for connection to field wiring.

Missing or defective sensors are detected and flagged by transmitting a value of less than 2mA to the receiver. Sensor elements are interchangeable with other R. C. Systems Inc. “smart” sensor products to reduce spare sensor inventory requirements.

The ST-49 functions with loop voltages ranging from 9 - 36VDC. Voltage drop across the ST-49 is less than 9 volts. An integral “transient voltage suppressor” protects the ST-49 and receiver devices in case of lightning or other surge voltage levels.

SPECIFICATIONS

SENSOR INTERFACE MODULE

Industry standard electrochemical type sensor with range configuration resistor and shorting transistor integrated into "smart" sensor module. 10-0242EC for "Series 7" or 10-0272EC for "Series 4" sensors

ANALOG OUTPUT

2-wire 4-20mA current sink; 9-36 VDC; less than 2mA FAULT value transmitted in case of missing or faulty sensor module.
Max output = 25mA

NRTL CSA APPROVALS (File # 219995)

ST-49 (10-0248) is Div. 1 & 2 Gr. A,B,C,D Exia. Suitable for Explosion Proof and Intrinsically Safe installations

ST-48IS (10-0248IS) without flame arrester is Div. 1 & 2 Gr. A,B,C,D. Suitable for Intrinsically Safe installations only

IMPORTANT: Intrinsically Safe installations require IS barrier # 10-0263 (MTL 7787P+) or equivalent.

CALIBRATION

None. Calibration function must be provided by the 4-20mA receiver. R. C. Systems Inc. ST-90, ST-71 & ST-72 controllers are designed to provide this function.

ACCURACY

± 5% of full scale.

AMBIENT TEMPERATURE RANGE

-40 - 60 degrees C

TEMPERATURE DRIFT

Less than .1% per degree C over ambient temperature range.

POWER SUPPLY

9-36 VDC @ 25mA

HOUSING

316 Stainless or aluminum (10-0248IS) enclosure suitable for Class 1, Groups A,B,C,D; Class 2, Groups E,F,G.

ORDERING INFORMATION

Part # 10-0248 = ST-49 Stainless Steel with flame arrester

Part # 10-0248IS = ST-49 Aluminum without flame arrester

"Series 4 or 7" industry standard Echem sensors supplied by user. Specify microamps full scale and when ordering. For sensors requiring bias, add "-BIAS" suffix when ordering and

ACCESSORIES:

*10-0242EC Series 7 Echem Interface PCB without sensor

*10-0272EC Series 4 Echem Interface PCB without sensor

10-0193 = ST-49 junction box

10-0198 = Sensor splash guard with remote calibration port

10-0203 = Sensor calibration cup

10-0205 = Sensor flow cell for process monitoring

10-0187 = Sensor replacement tool kit

*Either a Series 7 or Series 4 Sensor Interface PCB is required

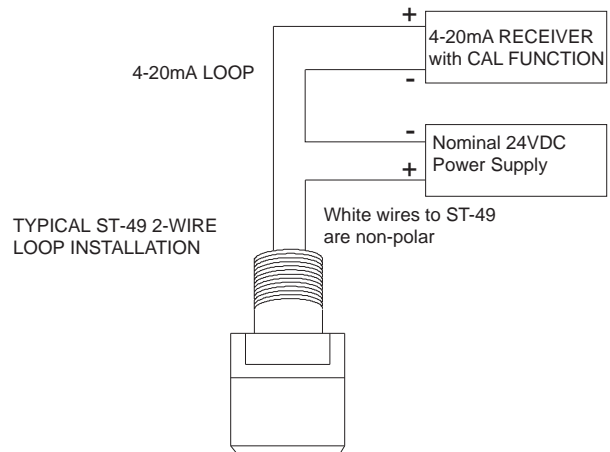

ALL DIMENSIONS IN INCHES

